

CliQ VA DIN Rail Power Supply

24V 240W 1 Phase / DRV-24V240W1PN



Highlights & Features

- Universal AC input voltage range
- LCD display monitoring the output current / voltage / peak current and temperature
- Life time expectancy alarm signal and monitoring
- Built-in active PFC with up to 94% efficiency
- Power Boost of 150% up to 7 seconds
- Advanced Power Boost (APB) – protect system and ensure continuing operation when large inrush current detected due to faulty load on a multiple load connection
- DC OK Contact and LED indicator for DC OK/ Overload
- Conformal coating on PCBAs to protect against common dust and chemical pollutants

Safety Standards



CB Certified for worldwide use

Model Number: DRV-24V240W1PN
Unit Weight: 1.02 kg (2.25 lb)
Dimensions (L x W x D): 124 x 60 x 139 mm (4.88 x 2.36 x 5.47 inch)

General Description

Delta Electronics introduces the CliQ VA DIN rail power supply series with LCD display. The LCD displays output current, output voltage, peak hold current, lifetime expectancy and ambient temperature data. The high power density product is designed according to major industrial safety standards. Similar to the CliQ M DIN rail series, CliQ VA provides 150% Power Boost up to 7 seconds, including the Advanced Power Boost (APB) feature. APB works in a way when large outrush current due to faulty load on a current path of a multiple loads connection is detected by APB, APB will trip the circuit breaker on that current path. This prevents the other connected loads from shutting down. Other features include compliance to harmonic current IEC/EN 61000-3-2, Class A, built-in DC OK contacts, and an LED for indicating DC OK and Overload conditions.

Model Information

CliQ VA DIN Rail Power Supply

Model Number	Input Voltage Range	Rated Output Voltage	Rated Output Current
DRV-24V240W1PN	85-276Vac (88-375Vdc)	24Vdc	10.0A

Model Numbering

DR	V –	24V	240W	1	P	N
DIN Rail	CliQ VA Series	Output Voltage	Output Power	Single Phase	Advanced Power Boost (APB)	N - Metal Case, without Class I, Div 2 and ATEX approvals



CliQ VA DIN Rail Power Supply

24V 240W 1 Phase / DRV-24V240W1PN



Specifications

Input Ratings / Characteristics

Nominal Input Voltage		100-240Vac	Applicable for TN-, TT and IT mains networks			
Input Voltage Range		85-276Vac	Continuously operating			
Input Frequency	Nom.	50-60Hz	±3% range (47-63Hz)			
Nominal DC Input Voltage		110-300Vdc				
DC input Voltage Range*		88-375Vdc	Continuously operating			
			100Vac	120Vac	230Vac	
Input Current	Typ.	2.63A	2.18A	1.16A	At 24V, 10A. Refer to Fig. 1	
	Max.	2.65A	2.22A	1.21A	At 24V, 10A.	
Efficiency	Typ.	91.90%	92.72%	94.73%	At 24V, 10A. Refer to Fig. 2	
	Min.	91.50%	92.60%	93.50%	At 24V, 10A.	
Average Efficiency	Typ.	90.87%	91.39%	92.71%	At 24V, 2.5A (25% load), 5.0A (50% load), 7.5A (75% load) 10A (100% load)	
	Min.	89.60%	90.20%	91.40%		
Max Power Dissipation	Typ.	2.87W	2.94W	3.00W	At 24V, 0A. Refer to Fig. 3	
	Max.	4.4W	4.9W	6.1W	At 24V, 0A.	
	Typ.	21.20W	18.90W	13.39W	At 24V, 10A. Refer to Fig. 3	
	Max.	22.4W	19.1W	16.7W	At 24V, 10A.	
Max Inrush Current (Cold Start)	Typ.	5.0A	6.0A	7.0A	Entire temperature range	
	Max.	10.0A				
Max Inrush Energy (Cold Start)	Max.	4A ² s				
Power Factor	Typ.	0.99	0.98	0.95	At 24V, 10A. Refer to Fig. 4	
	Min.	0.99	0.98	0.92	At 24V, 10A.	
Crest Factor	Max.	1.65	1.67	1.85	At 24V, 10A.	
Leakage Current (Enclosure to Neutral)		< 0.28mA / 0.80mA < 0.38mA / 0.95mA < 0.74mA / 2.10mA			110Vac, 50Hz, TN/TT system / IT system 132Vac, 50Hz, TN/TT system / IT system 264Vac, 50Hz, TN/TT system / IT system	

*Safety approval according to IEC/EN/UL 60950-1.

CliQ VA DIN Rail Power Supply

24V 240W 1 Phase / DRV-24V240W1PN

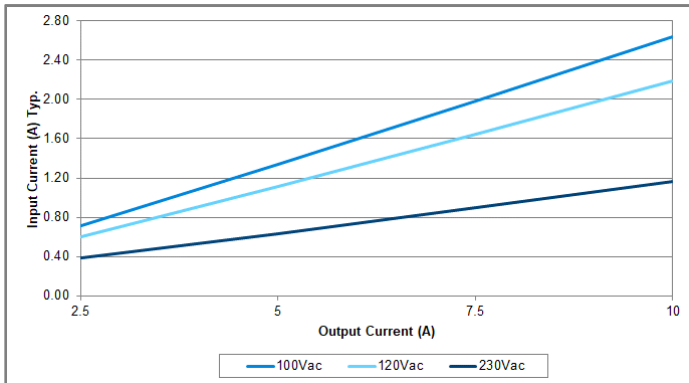

Fig. 1 Input Current Vs Output Load at 24V

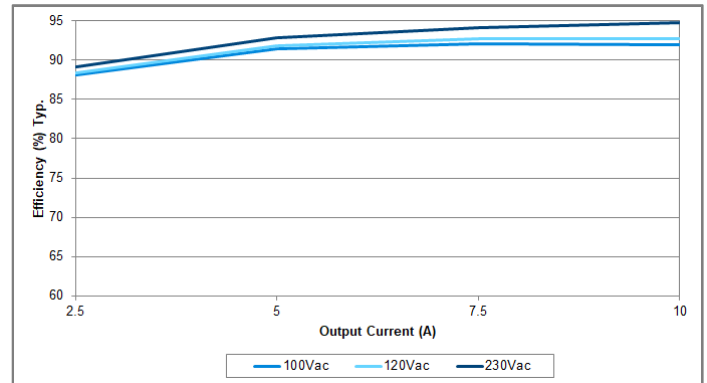

Fig. 2 Efficiency Vs Output Load at 24V

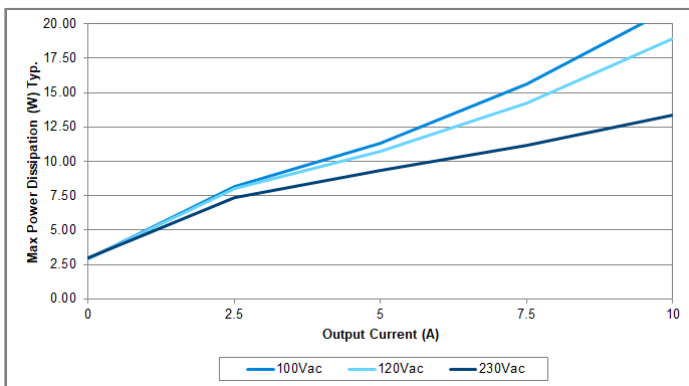

Fig. 3 Max Power Dissipation Vs Output Load at 24V

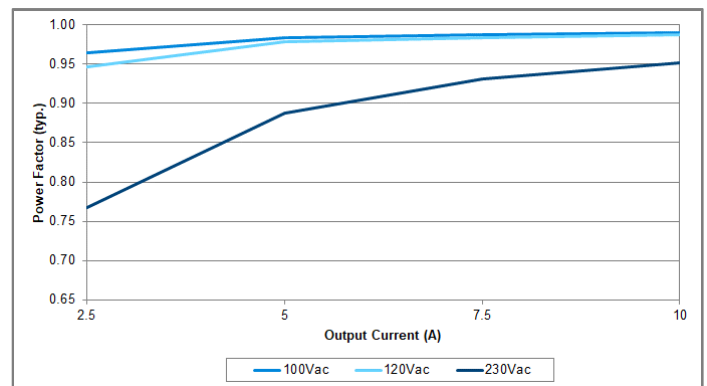

Fig. 4 Power Factor Vs Output Load at 24V



CliQ VA DIN Rail Power Supply

24V 240W 1 Phase / DRV-24V240W1PN



Output Ratings / Characteristics*

Nominal Output Voltage	24Vdc		
Factory Set Point Tolerance	24Vdc \pm 1.0%		
Output Voltage Adjustment Range	24-28Vdc		
Output Current	Nom.	10.0A / 8.57A	Continuously operating at 24V / 28V Power Boost for 5 seconds at 24V / 28V, refer to the details in the Functions section
	Nom.	15.0A / 13.5A (Slew rate 0.1A/ μ s)	
Output Power	Nom.	240W / 240W	Continuously operating at 24V / 28V Power Boost for 5 seconds at 24V / 28V, refer to the details in the Functions section
	Nom.	360W / 378W	
Power Boost Duration	Typ.	5 seconds	Duration after which output voltage start to droop, refer to the details in the Function section at Overload & Overcurrent Protections
	Max.	7 seconds	
Power Boost Recovery Time	Typ.	14 seconds	Required wait duration before next Power Boost is taken, refer to the details in the Function section
Advanced Power Boost (Slew rate 0.1A/ μ s)	Typ.	20A @ 50ms, resistive load	Output voltage will drop (Refer to the details in the Function section)
	Typ.	50A @ 2ms, resistive load	
	Typ.	50A @ 5ms, resistive load	
Line Regulation	Max.	10mV (@ 85-276Vac input, 100% load)	
Load Regulation	Max.	100mV (@ 85-276Vac input, 0-100% load)	
PARD**	Max.	50mVpp	20Hz to 20MHz, 50Ohm, warm up for 10mins

*For power de-rating from 60°C to 70°C, see power de-rating on page 10.

**PARD is measured with an AC coupling mode, 5cm wires, and in parallel with 0.1 μ F ceramic capacitor & 47 μ F electrolytic capacitor.

		100Vac	120Vac	230Vac	
Rise Time	Max.	100ms			0 μ F, 24V, 10A.
	Max.	120ms			10,000 μ F, 24V, 10A.
Start-up Time	Max.	800ms	650ms	340ms	At 24V, 10A.
Hold-up Time	Typ.	92ms			At 24V, 5A.
	Min.	55ms			At 24V, 5A.
	Typ.	46ms			At 24V, 10A.
	Min.	28ms			At 24V, 10A.
Dynamic Response (Overshoot & Undershoot O/P Voltage)	Max.	\pm 5% @ 0-100% load			Slew rate 0.1A/ μ s (@ 5Hz, 50Hz & 1kHz, 50% Duty Cycle)
Start-up with Capacitive Loads	Max.	10,000 μ F			
Output Capacitance	Typ.	7,000 μ F			Built-in output capacitors
Functional	DC OK Relay Contact	Rated: 30V at 1A, resistive load The relay contact are normally "ON" (closed) when the output (Vout) is greater than 90% of its rated value. (Refer to the details in the Function section)			
	Years alarm signal	Rated: 30V Max. with sink current of 10mA Max.			

CliQ VA DIN Rail Power Supply

24V 240W 1 Phase / DRV-24V240W1PN



Mechanical

Case Cover / Chassis	Aluminium and Plastic / Aluminium	
Dimensions (L x W x D)	124 x 60 x 139 mm (4.88 x 2.36 x 5.47 inch)	
Unit Weight	1.02 kg (2.25 lb)	
Indicator	Green LED (DC OK) and Red LED (Overload)	
Cooling System	Convection	
Terminal	Input	3 Pins (Rated 600V/35A)
	Output	6 Pins (Rated 300V/28A)
	Signal	2 Pins (Rated 300V/10A)
Wire	Input	AWG 18-8
	Output	AWG 16-12
	Signal	AWG 20-16
Mounting Rail	Standard TS35 DIN Rail in accordance with EN 60715	
Noise (1 Meter from power supply)	Sound Pressure Level (SPL) < 25dBA	

Environment

Surrounding Air Temperature	Operating	-25°C to +70°C
	Storage	-40°C to +85°C
Power De-rating	Vertical Mounting	> 60°C de-rate power by 2.5% / °C
	Horizontal Mounting	> 50°C de-rate power by 2.5% / °C
Operating Humidity	5 to 95% RH (Non-Condensing)	
Operating Altitude	0 to 5,000 Meters (16,400 ft.)	
Shock Test	Non-Operating	IEC60068-2-27, Half Sine Wave: 30G for a duration of 18ms; 3 times per direction, 6 times in total
Vibration	Non-Operating	IEC 60068-2-6, Sine Wave: 10-500Hz; 3G peak; displacement of 0.35mm; 60 min per axis for all X, Y, Z directions
Bump Test	Operating	IEC 60068-2-29, Half Sine Wave: 10G for a duration of 11ms, 1,000 times per direction, 6,000 times in total
Over Voltage Category	III	According to IEC/EN 62477-1 / EN 60204-1 (clearance and creepage distances) and IEC 62103 (safety part)
Pollution Degree	2	

CliQ VA DIN Rail Power Supply

24V 240W 1 Phase / DRV-24V240W1PN



Protections

Overvoltage	28.8 – 35.2V, SELV Output, Hiccup Mode, Non-Latching (Auto-Recovery)	Refer to the details in the Function section
Overload / Overcurrent	> 150% of rated load current, Constant current limit, Auto-Recovery when the fault is removed	Refer to the details in the Function section
Over Temperature	< 80°C Surrounding Air Temperature @ 100% load, Non-Latching (Auto-Recovery)	Refer to the details in the Function section
Short Circuit	Hiccup Mode, Non-Latching (Auto-Recovery when the fault is removed)	Load impedance ≤ 100mOhm, refer to the details in the Function section
Transient Surge Voltage Protection	MOV (Metal Oxide Varistor)	
Internal Fuse at L pin	T6.3A	
Degree of Protection	IP20	
Protection Against Shock	Class I with PE* connection	

*PE: Primary Earth

Reliability Data

MTBF (as per Telcordia SR-332)	1,268,000 hrs.	I/P: 100Vac, O/P: 24V, 10A, Ta: 25°C	
	666,000 hrs.	I/P: 100Vac, O/P: 24V, 10A, Ta: 40°C	
Expected Cap Life Time**	100Vac	230Vac	
	131,400hrs.		O/P: 24V, 10A, Ta: 25°C
	81,490hrs.	121,350hrs.	O/P: 24V, 10A, Ta: 40°C
	131,400hrs.		O/P: 24V, 5A, Ta: 40°C

**Estimated lifetime when 24 hours operating a day and E-cap's manufacturer guarantee at 131,400 hrs (15 years) as maximum limit of lifetime.

CliQ VA DIN Rail Power Supply

24V 240W 1 Phase / DRV-24V240W1PN



Safety Standards / Directives

Electrical Equipment of Machines		EN 60204-1 (over voltage category III)
Electrical Equipment for Use in Electrical Power Installations		IEC/EN 62477-1 / IEC 62103
Safety Entry Low Voltage		PELV* (EN 60204-1), SELV (EN 60950-1)
Electrical Safety	SIQ Bauart	EN 60950-1, EN 61010-1, EN 61010-2-201
	UL/cUL recognized	UL 60950-1 and CSA C22.2 No. 60950-1 (File No. E191395)
	CB scheme	IEC 60950-1, IEC 61010-1, IEC 61010-2-201
Industrial Control Equipment	UL/cUL listed	UL 508 and CSA C22.2 No. 107.1-01 (File No. E315355)
CE		In conformance with EMC Directive 2014/30/EU and Low Voltage Directive 2014/35/EU
Material and Parts		RoHS Directive 2011/65/EU Compliant
Galvanic Isolation	3.0KVac	Input / Output
	2.0KVac	Input / PE
	3.0KVac	Input / DC OK relay contact**
	1.5KVac	Output / PE
	0.5KVac	Output / DC OK relay contact
	1.5KVac	DC OK relay contact / PE
Isolation Resistance	> 5M Ω	Input to Output, 500Vdc
PE Resistance	< 0.1 Ω	

*Output must be earthed in the final unit in order to comply with PELV requirements according to standard EN 60204-1.

**Recommend to connect DC OK pins together with output pins.

CliQ VA DIN Rail Power Supply

24V 240W 1 Phase / DRV-24V240W1PN



EMC

Emissions (CE & RE)		Generic Standards: EN 61000-6-3 CISPR 32, EN 55032, CISPR 11, EN 55011, FCC Title 47: Class B		
Component Power Supply for General Use		EN 61204-3		
Immunity		Generic Standards: EN 55024, EN 61000-6-2		
Electrostatic Discharge	IEC 61000-4-2	Level 4 Criteria A ¹⁾ Air Discharge: 15kV Contact Discharge: 8kV		
Radiated Field	IEC 61000-4-3	Level 3 Criteria A ¹⁾ 80MHz-1GHz, 10V/M, 80% modulation (1kHz) 1.4GHz-2GHz, 3V/M, 80% modulation (1KHz) 2GHz-2.7GHz, 1V/M, 80% modulation (1KHz)		
Electrical Fast Transient / Burst	IEC 61000-4-4	Level 4 Criteria A ¹⁾ 4kV		
Surge	IEC 61000-4-5	Level 4 Criteria A ¹⁾ Common Mode ³⁾ : 4kV Differential Mode ⁴⁾ : 2kV		
Conducted	IEC 61000-4-6	Level 3 Criteria A ¹⁾ 150kHz-80MHz, 10Vrms		
Power Frequency Magnetic Fields	IEC 61000-4-8	Criteria A ¹⁾ 30A/Meter		
Voltage Dips and Interruptions	IEC 61000-4-11	0% of 100Vac 40% of 100Vac 70% of 100Vac 0% of 200Vac 40% of 200Vac 70% of 200Vac 0% of 200Vac	0Vac, 20ms 40Vac, 200ms 70Vac, 500ms 0Vac, 20ms 80Vac, 200ms 140Vac, 500ms 0Vac, 5000ms	Criteria A ¹⁾ Criteria B ²⁾ Criteria A ¹⁾ Criteria A ¹⁾ Criteria A ¹⁾ Criteria A ¹⁾ Criteria B ²⁾
Low Energy Pulse Test (Ring Wave)	IEC 61000-4-12	Level 3 Criteria A ¹⁾ Common Mode ³⁾ : 2kV Differential Mode ⁴⁾ : 1kV		
Harmonic Current Emission		IEC/EN 61000-3-2, Class A		
Voltage Fluctuation and Flicker		IEC/EN 61000-3-3		
Voltage Sag Immunity SEMI F47 – 0706		80% of 120Vac 70% of 120Vac 50% of 120Vac	96Vac, 1000ms 84Vac, 500ms 60Vac, 200ms	Criteria A ¹⁾ Criteria A ¹⁾ Criteria A ¹⁾

1) Criteria A: Normal performance within the specification limits
 2) Criteria B: Temporary degradation or loss of function which is self-recoverable
 3) Asymmetrical: Common mode (Line to earth)
 4) Symmetrical: Differential mode (Line to line)



CliQ VA DIN Rail Power Supply

24V 240W 1 Phase / DRV-24V240W1PN



Block Diagram

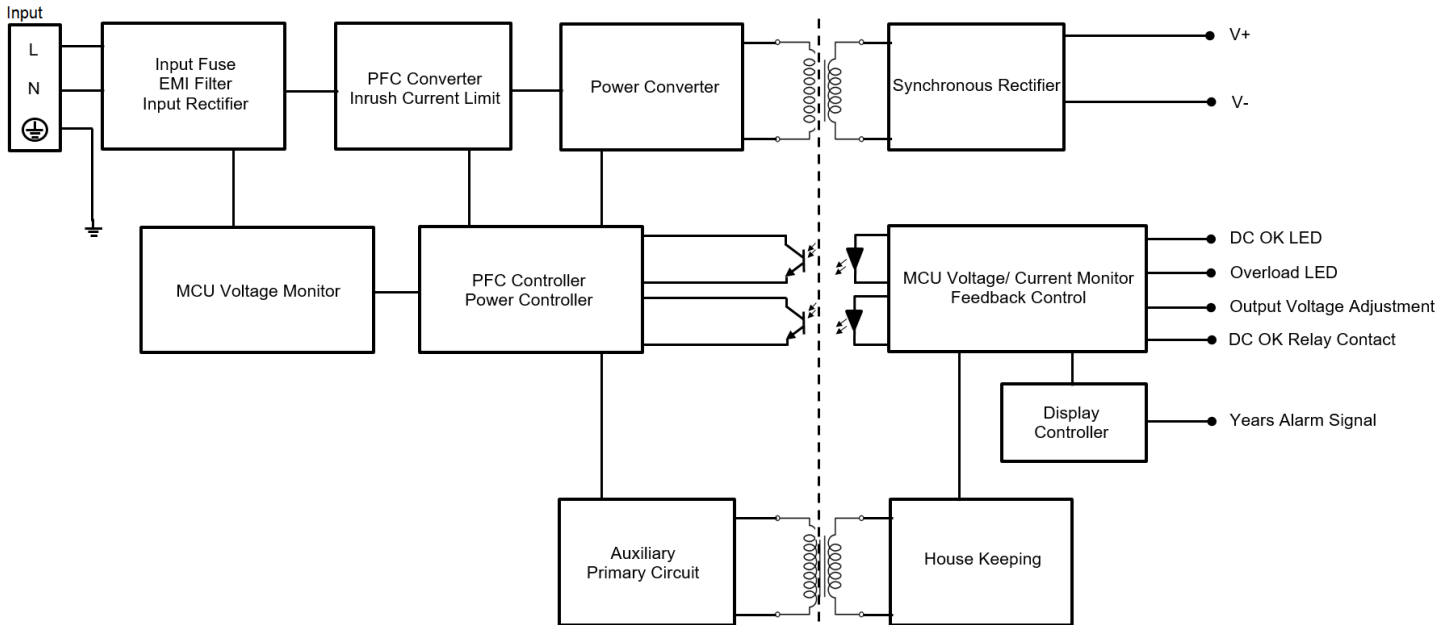

Device Description

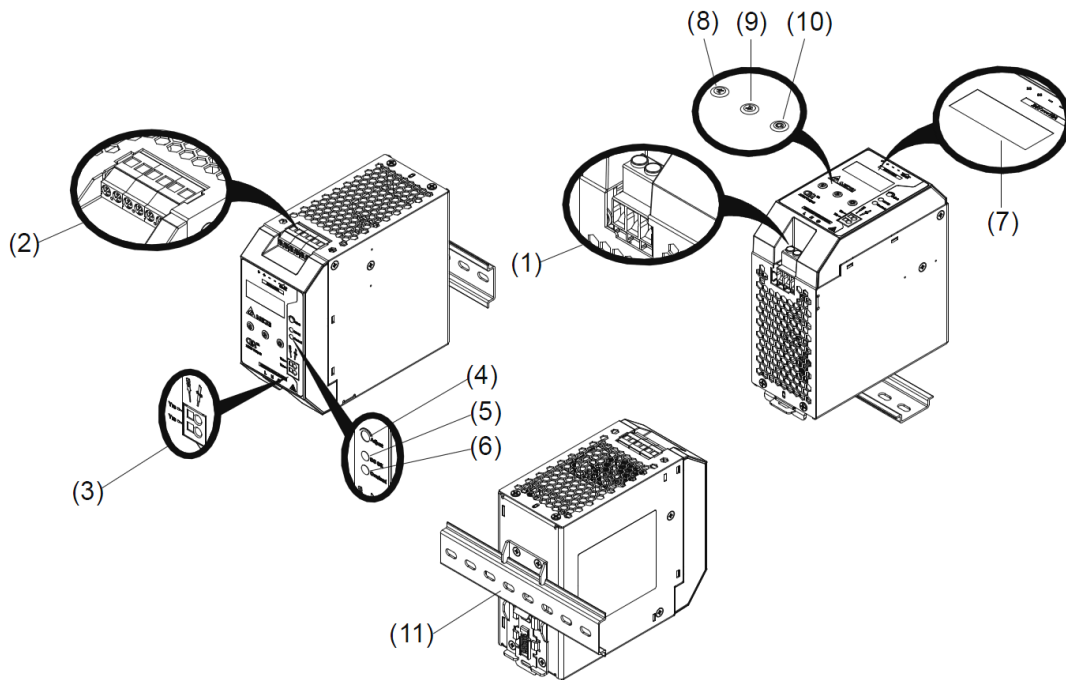

- | | |
|--|------------------------------------|
| 1) Input terminal block connector | 7) LCD display |
| 2) Output and DC OK relay contact terminal block connector | 8) Back key |
| 3) Years alarm signal terminal block connector | 9) Forward key |
| 4) DC Voltage adjustment potentiometer | 10) Mode key |
| 5) DC OK LED (Green) | 11) Universal mounting rail system |
| 6) Overload LED (Red) | |

CliQ VA DIN Rail Power Supply

24V 240W 1 Phase / DRV-24V240W1PN



Dimensions

L x W x D: 124 x 60 x 139 mm (4.88 x 2.36 x 5.47 inch)

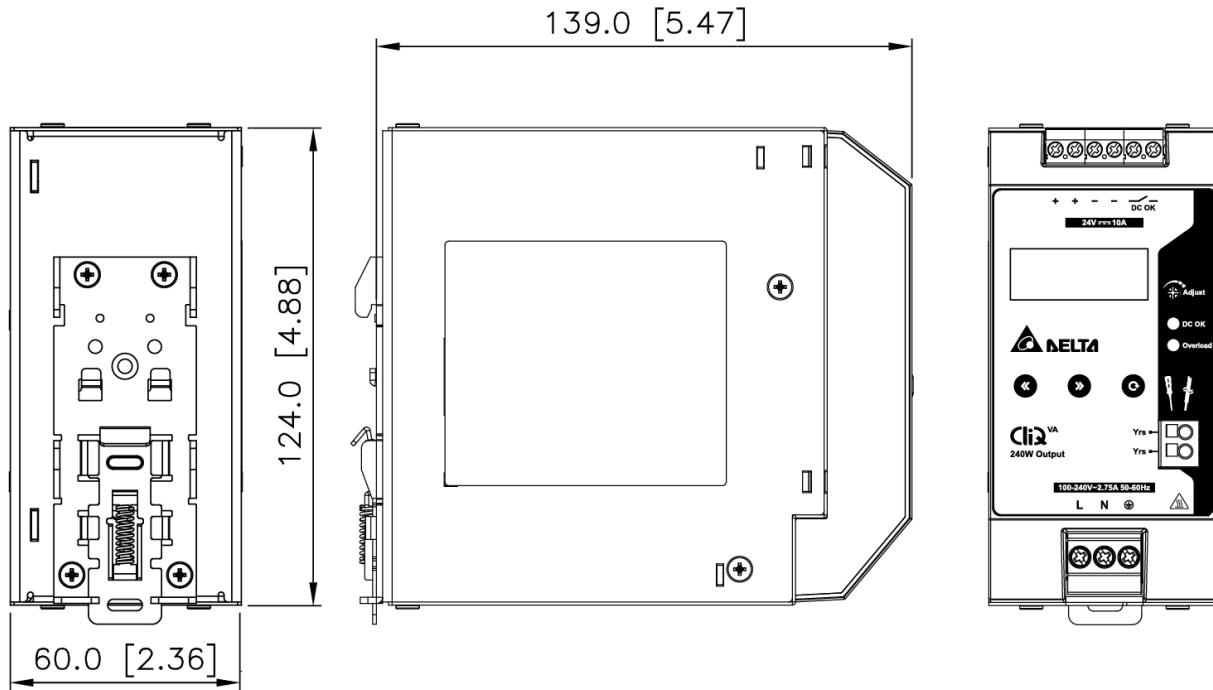

Engineering Data

Output Load De-rating VS Surrounding Air Temperature

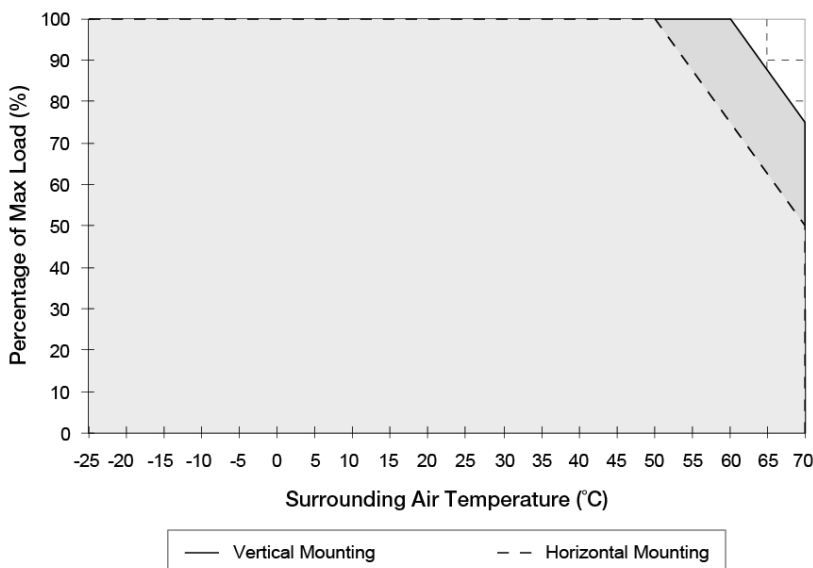

Fig. 5 De-rating for Vertical Mounting Orientation
 > 60°C de-rate power by 2.5% / °C

De-rating for Horizontal Mounting Orientation
 > 50°C de-rate power by 2.5% / °C

Note

1. Power supply components may degrade, or be damaged, when the power supply is continuously used outside the shaded region, refer to the graph shown in Fig. 1.
2. If the output capacity is not reduced when the surrounding air temperature >60°C (Vertical) or >50°C (Horizontal), the device will run into Over Temperature Protection. When activated, the output voltage will go into bouncing mode and will recover when the surrounding air temperature is lowered or the load is reduced as far as necessary to keep the device in working condition.
3. In order for the device to function in the manner intended, it is also necessary to keep a safety distance as recommended in the safety instructions while the device is in operation.
4. Depending on the surrounding air temperature and output load delivered by the power supply, the device can be very hot!
5. If the device has to be mounted in any other orientation, please contact info@deltapsu.com for more details.



CliQ VA DIN Rail Power Supply

24V 240W 1 Phase / DRV-24V240W1PN



Output Load De-rating VS Input Voltage

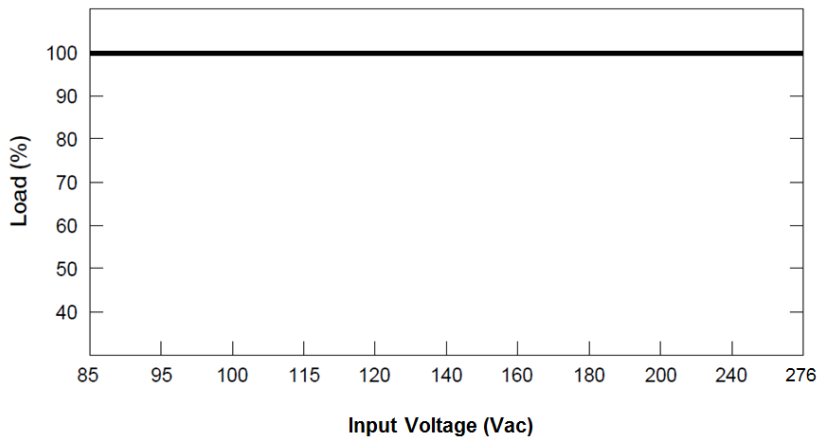

■ No output power de-rating for the input voltage range

Assembly & Installation

The power supply unit (PSU) can be mounted on 35mm DIN rails in accordance with EN 60715. For Vertical Mounting, the device should be installed with input terminal block at the bottom. For Horizontal Mounting, the device should be installed with input terminal block on the left side.

Each device is delivered ready to install.

1. Tilt the unit upwards and insert it onto the DIN rail. Snap on the DIN rail as shown in Fig. 6.1.
2. Push downwards until stopped.
3. Press against the bottom front side for locking.
4. Shake the unit slightly to ensure that it is secured.
5. To uninstall, pull or slide down the latch with screw driver as shown in Fig. 6.2. Then slide the power supply unit (PSU) in the opposite direction, release the latch and pull out the power supply unit (PSU) from the rail.

Mounting

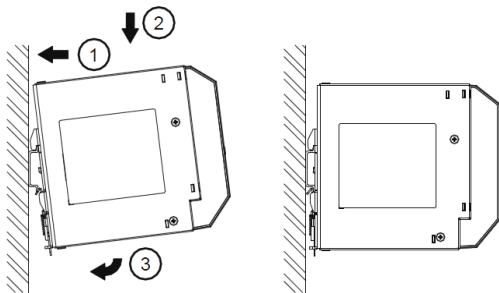

Fig. 6.1 Mounting

Dismounting

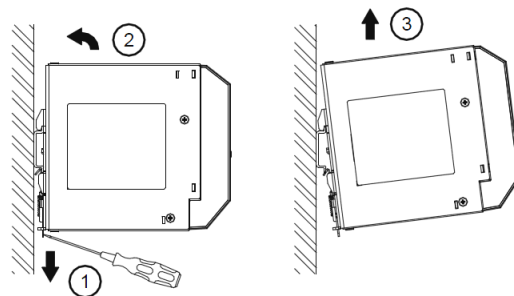

Fig. 6.2 Dismounting

In accordance to EN 60950 / UL 60950, flexible cables require ferrules. Use appropriate copper cables designed to sustain operating temperature of:

1. 60°C, 60°C / 75°C for USA
2. At least 90°C for Canada and IEC/EN61010-1, IEC/EN61010-2-201.

CliQ VA DIN Rail Power Supply

24V 240W 1 Phase / DRV-24V240W1PN



Safety Instructions

■ Vertical Mounting

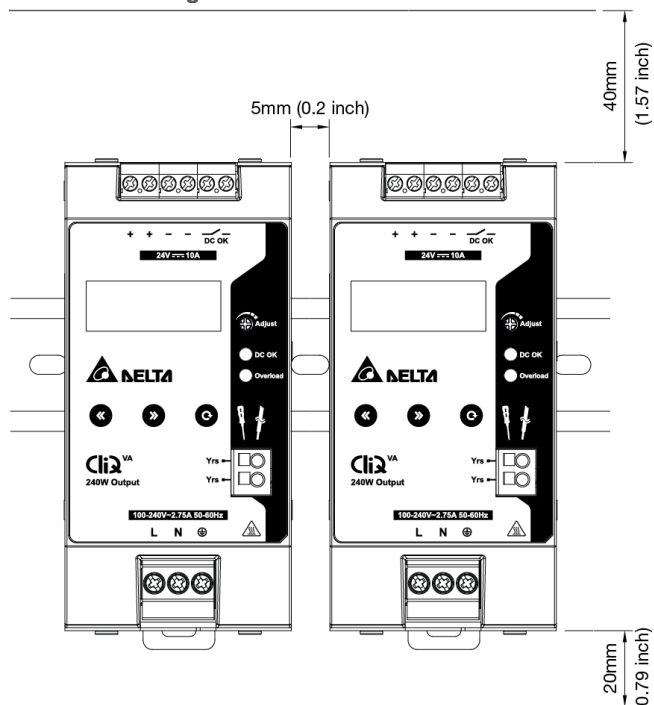

■ Horizontal Mounting

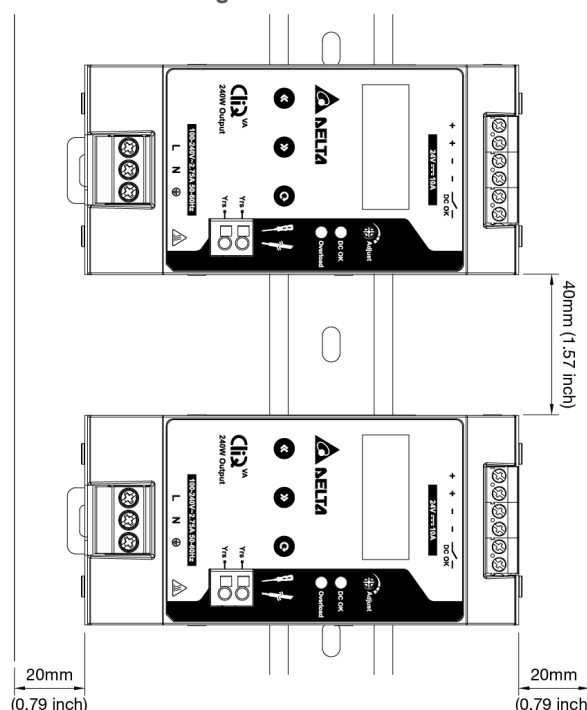

- An easily accessible disconnecting device shall be provided to disconnect the unit from the mains supply for servicing.
- ALWAYS switch mains of input power OFF before connecting and disconnecting the input voltage to the device. If mains are not turned OFF, there is risk of explosion / severe damage.
- If the unit is used in a manner not specified by the manufacturer, the protection provided by the equipment may be impaired.
- **To guarantee sufficient convection cooling, please refer to the following instructions to ensure sufficient clearance around the device.**

Vertical Mounting: 40mm (1.57 inch) above and 20mm (0.79 inch) below the device as well as a lateral distance of 5mm (0.2 inch) to other units. In case the adjacent device is a heat source, the lateral distance will be 15mm (0.6 inch).

Horizontal Mounting: 40mm (1.57 inch) above and below the device as well as a lateral distance of 20mm (0.79 inch) to other units.

- The external enclosure where the unit will be installed shall meet the requirements for mechanical, electrical and fire enclosure.
- Note that the enclosure of the device can become very hot depending on the surrounding air temperature and output load connected to the device. Risk of burns!
- The main power must be turned off before connecting or disconnecting wires to the terminals.
- DO NOT insert any objects into the unit.
- Dangerous voltages present for at least 5 minutes after disconnected all sources of power.
- The power supplies are built in units and must be installed in a cabinet or room (condensation free environment and indoor location) that is relatively free of conductive contaminants.



CliQ VA DIN Rail Power Supply

24V 240W 1 Phase / DRV-24V240W1PN



Functions

DC OK Relay Contacts and LED Indicator Characteristics

DC OK Relay Contacts Status	Characteristics
Contact closes	The output voltage reaches 95% of its steady state set value. The contact will close within 1000ms.
Contact opens	The output voltage dip lower than 90% of its steady state set value: <ul style="list-style-type: none"> Output voltage dip duration less than 2ms will be ignored. Output voltage dip duration more than 2ms. The contact will open within 15ms and remain open for an extended duration up to 350ms max.
Contact re-closes	The output voltage reaches 90% of its steady state set value. The contact will close in 350ms max.

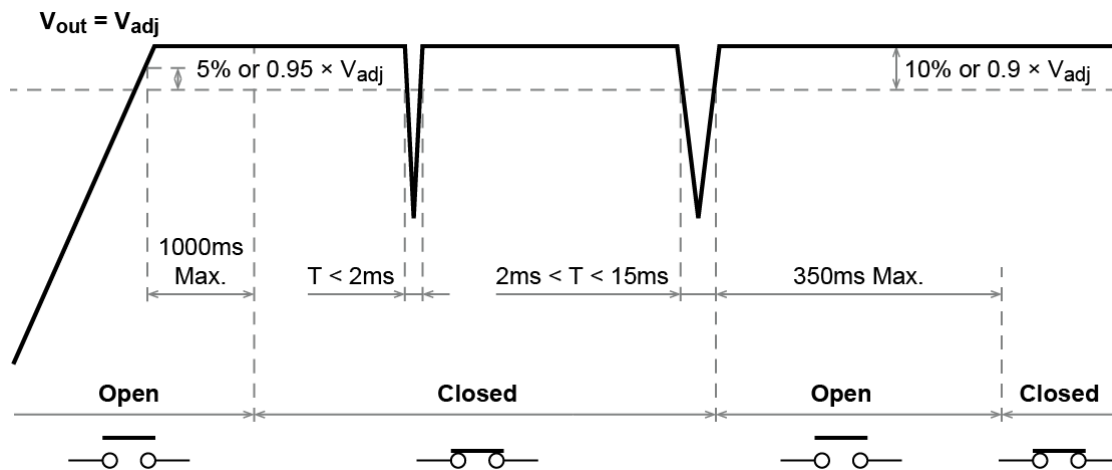

CliQ VA Status	DC OK (Green LED)	Overload (Red LED)	DC OK Relay Contact
Normal Operation	ON	OFF	Closed
During Power Boost	ON	OFF	Closed
Overload ($V_{out} \leq 90\%$ of adjusted voltage)	OFF	Flashing	Open
Output Short Circuit	OFF	Flashing	Open
Over Temperature	OFF	Flashing	Open
No Input Power	OFF	OFF	Open

CliQ VA DIN Rail Power Supply

24V 240W 1 Phase / DRV-24V240W1PN



Display Functions and Operating Procedures

LCD module has the function to display the output voltage, output current, peak hold current, lifetime expectancy, ambient temperature, KWH in "Display Mode" and set years alarm value, reset peak hold current/KWH in "Setting Mode".

Years alarm signal checking mode and failure display mode are also available in this CliQ VA series.

■ Mode Change

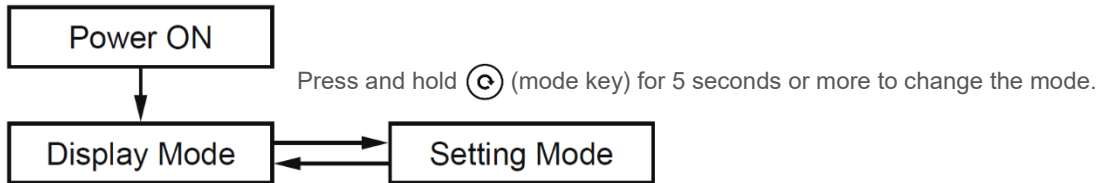

■ Display Mode

- By default, the power supply unit is set to auto display mode and will show the status in the following sequence below.
- Press Ⓞ (mode key) to freeze the current indicated status on the LCD display.
- Press ⏪ or ⏩ (back or forward key) to move between each status.
- Press Ⓞ (mode key) to return to auto display mode.

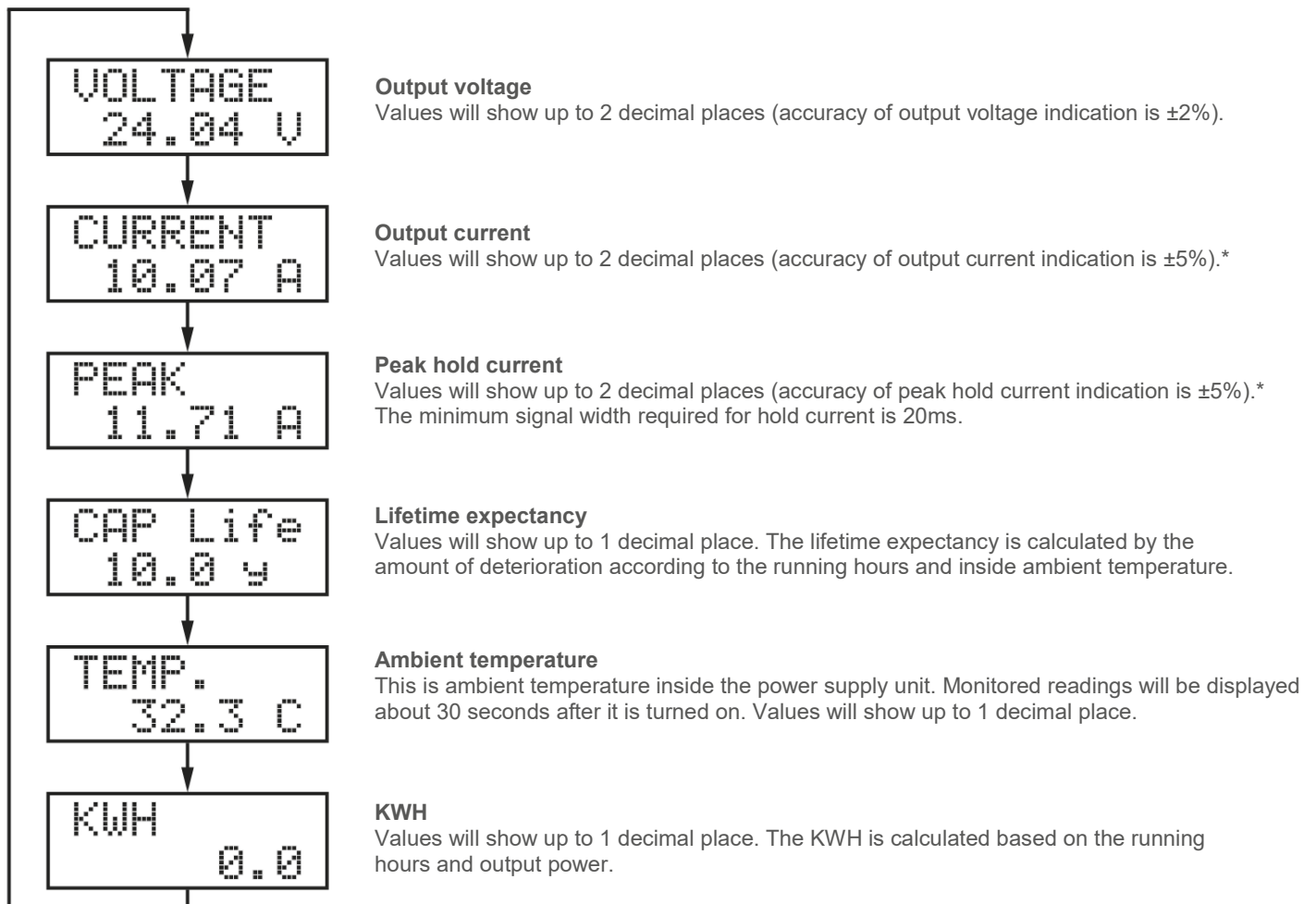

*If Io < 5%, accuracy is ±10%.

CliQ VA DIN Rail Power Supply

24V 240W 1 Phase / DRV-24V240W1PN



■ Setting Mode

- Press and hold (mode key) for 5 seconds or more to change from “Display Mode” to “Setting Mode”.
- The power supply unit will show the items in the following sequence below.

1) Years Alarm



- The display will show years alarm with the current setting, years alarm signal is counting the total running time of power supply. The user could be using this signal for maintenance forecast.
- Press or (back or forward key) to increase or decrease the alarm setting. (Factory setting is default 10.0 years and minimum setting is 0.5 years.)
- Once the desired value is SET, press (mode key) for 5 seconds or more to finish the task. The display will be changed to “Display Mode” after finish the years alarm setting.

Note: To return to auto display mode, press and hold (mode key) for 5 seconds or more.

2) Reset



- The display will show years alarm with the current setting.
- Press (mode key) to go to “RESET”.
- Press (back key) to select peak hold current or press (forward key) to select KWH.

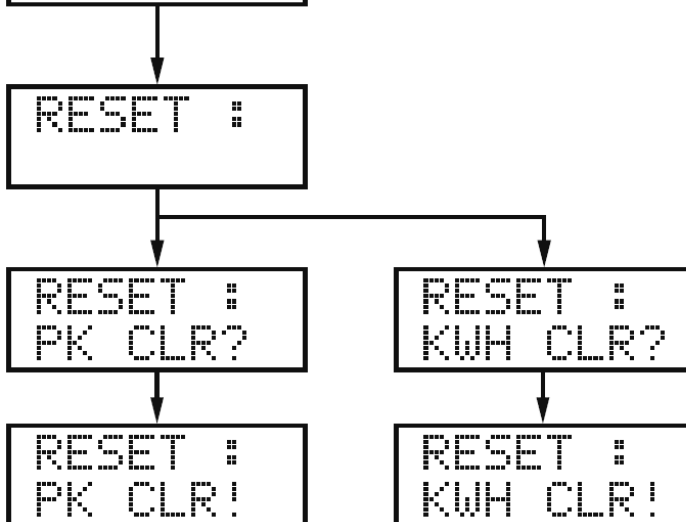

Press (mode key) to confirm and clear peak hold current or KWH value.

Note: To return to auto display mode, press and hold (mode key) for 5 seconds or more.

CliQ VA DIN Rail Power Supply

24V 240W 1 Phase / DRV-24V240W1PN



■ Years Alarm Signal Checking Mode

- The CliQ VA series has function “speed up check” for years alarm signal.
- Press ⏪ and ⏩ together (back and forward key) for 5 seconds or more to change from “Display Mode” to “Years Alarm Signal Checking Mode”.
- The power supply unit will show the items in the following sequence below.



- The display will be changed to “Years Alarm Signal Checking Mode”.
- Press ⏪ (mode key) to confirm years alarm signal check.
- The program will start counting running time (speed up) from 10 years back to the alarm year as original setting.



- After counting is complete, display will be changed to years alarm signal check OK.

Note: To return to auto display mode, press and hold ⏪ (mode key) for 5 seconds or more.

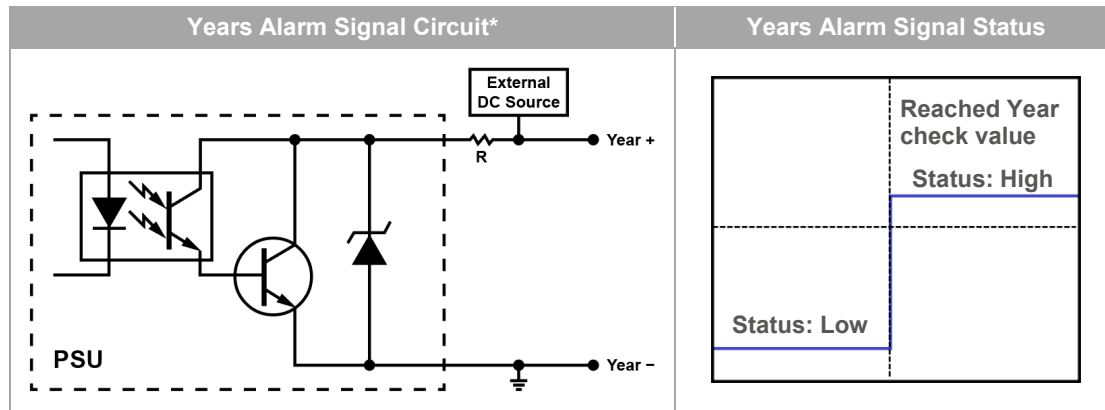

- The years alarm signal status is Low when the set value of alarm year has not been reached.
- The years alarm signal status will be changed from Low to High when the set value of alarm year has been reached.

*The applied voltage should be 30V Max. with sink current of 10mA Max.

■ Failure Mode Display

- There are failure mode display for power supply protections as below.
- Press ⏪ (mode key) to clear error messages and return to auto display mode.

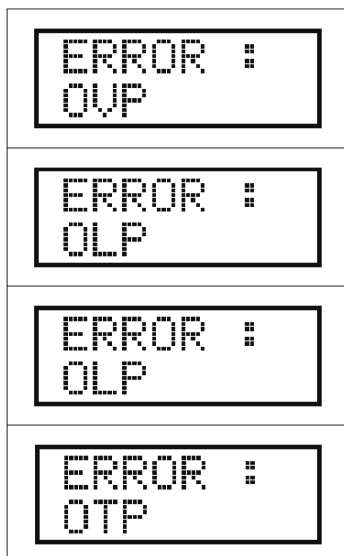

When overvoltage protection occurs (Auto-recovery)

When overload/over current protection occurs (Auto-recovery)

When short circuit protection occurs (Auto-recovery)

When over temperature protection occurs (Auto-recovery)

CliQ VA DIN Rail Power Supply

24V 240W 1 Phase / DRV-24V240W1PN



■ Graph illustrating the Start-up Time, Rise Time, and Hold-up Time

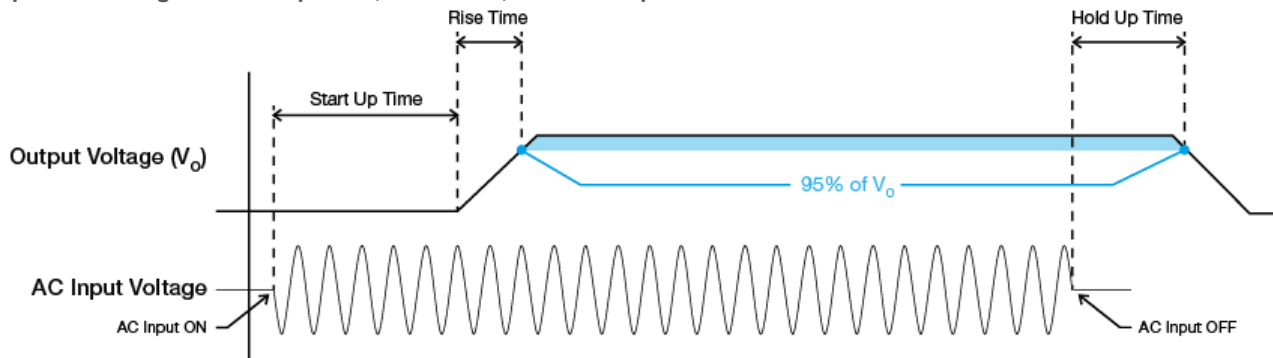

Start-up Time

The time required for the output voltage before output voltage rise up, after the input voltage is applied.

Rise Time

The time required for the output voltage to change from 0% to 95% of its final steady state set value.

Hold-up Time

Time between the collapse of the AC input voltage, and the output falling to 95% of its steady state set value.

CliQ VA DIN Rail Power Supply

24V 240W 1 Phase / DRV-24V240W1PN



Inrush Current

Inrush current is the peak, instantaneous, input current measured and, occurs when the input voltage is first applied. For AC input voltages, the maximum peak value of inrush current will occur during the first half cycle of the applied AC voltage. This peak value decreases exponentially during subsequent cycles of AC voltage.

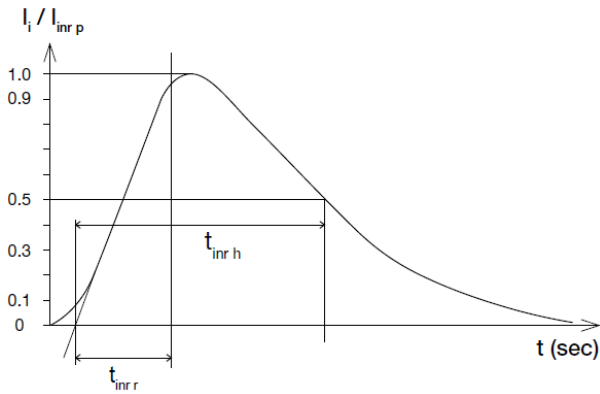

Dynamic Response

The power supply output voltage will remain within $\pm 5\%$ of its steady state value, when subjected to a dynamic load from 0 to 100% of its rated current.

■ 50% duty cycle / 5Hz to 1KHz

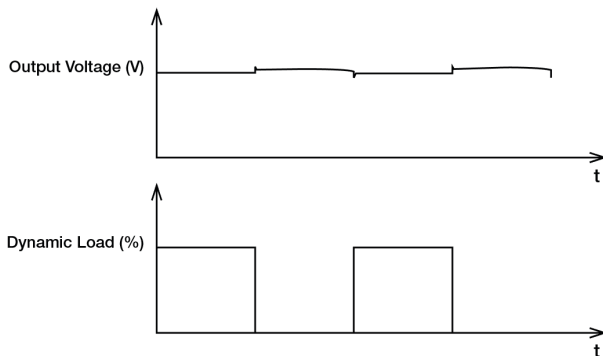

Overvoltage Protection (Auto-Recovery)

The power supply's overvoltage circuit will be activated when its internal feedback circuit fails. The output voltage shall not exceed its specifications defined on Page 6 under "Protections".

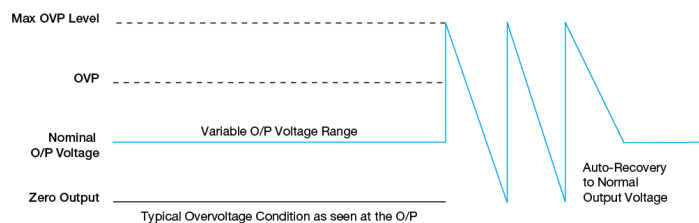

Overload & Overcurrent Protections (Auto-Recovery)

The power supply's Overload (OLP) and Overcurrent (OCP) Protections will be activated when output current is $> 150\%$ of I_o (output current). Upon such an occurrence, the output current will limit to 11A typ., refer to (A) and V_o (output voltage) will start to droop and operate in "Constant Current mode". The power supply will recover once the fault condition due to OLP or OCP is removed, then I_o is back within the specified range

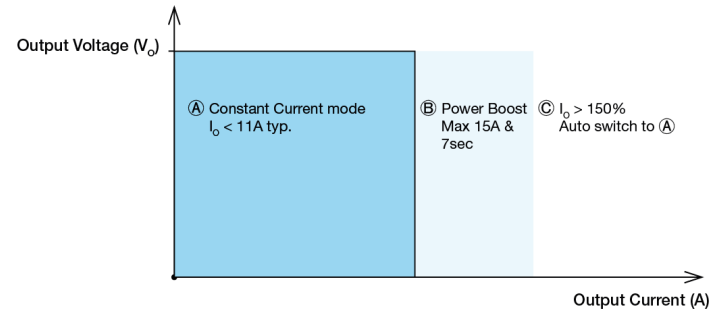

Short Circuit Protection (Auto-Recovery)

The power supply's output Short Circuit Protection function also provides protection against short circuits. When a short circuit is applied, the output current will operate in "Hiccup mode". The power supply will return to normal operation after the short circuit is removed.

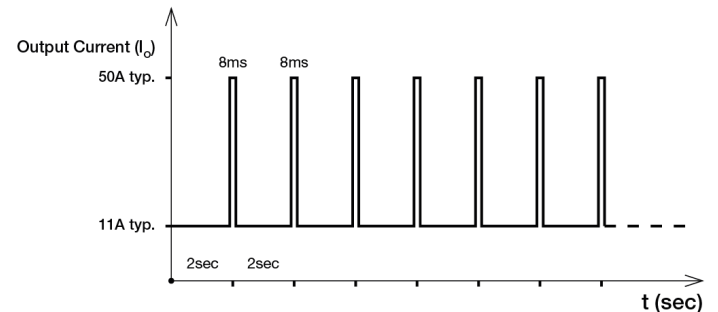

Over Temperature Protection (Auto-Recovery)

As described in load de-rating section, the power supply also has Over Temperature Protection (OTP). In the event of a higher operating temperature at 100% load, the power supply will run into OTP when the operating temperature is beyond what is recommended in the de-rating graph. When activated, the output voltage will go into bouncing mode until the temperature drops to its normal operating temperature as recommended in the de-rating graph.

CliQ VA DIN Rail Power Supply

24V 240W 1 Phase / DRV-24V240W1PN



Power Boost

Power Boost is the reserve power available constantly that allows reliable startup to support sudden and short spike of loads with high inrush current typically during turn on to remove the need of more expensive higher rated power supply unit. After the output has reached its steady state set value, the power supply can support surge loads with a higher short-term power demand up to 150% of maximum rated load ($I_o \text{ Max}$), for a maximum duration of 7 seconds. If the power boost lasts longer than maximum duration, the output current will limit to 11A typ. and V_o (output voltage) will start to droop and operate in "Constant Current mode". The Power Boost is repetitive, need to maintain the duty cycle & recovery time to ensure that average (R.M.S) output power shall not exceed the continuous maximum, see duty cycle calculation below.

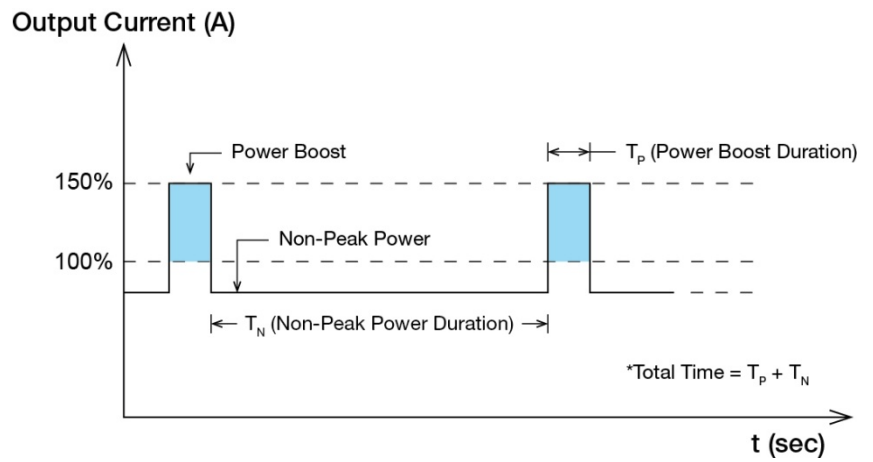

Fig. 7 Duty Cycle Calculation

$$\text{Duty cycle (\%)} = \frac{T_p}{\text{Total Time}}$$

$$\text{Average Output Power (P}_{Avg}\text{)} = \frac{(\text{Power Boost} \times T_p) + (\text{Non-Peak Power} \times T_n)}{\text{Total Time}}$$

OR

$$\text{Non-Peak Power} = \frac{(\text{P}_{Avg} \times \text{Total Time}) - (\text{Power Boost} \times T_p)}{T_n}$$

■ An example of Power Boost and Average Output Power

Power Boost	Peak Power (W _P)	Power Boost Duration (T _P)	Duty Cycle	Non-Peak Power (W _N)	Non-Peak Power Duration (T _N)	Total Time (T)
150%	360	7 sec	10%	226W	60 sec	67 sec
150%	360	7 sec	30%	188W	16 sec	23 sec
120%	288	7 sec	10%	234W	60 sec	67 sec
120%	288	7 sec	30%	219W	16 sec	23 sec

It is not recommended to extend the duration of Power Boost to be longer than the specified duty cycle calculation, this may cause damage to the PSU.

CliQ VA DIN Rail Power Supply

24V 240W 1 Phase / DRV-24V240W1PN



Advanced Power Boost (APB)

With multiple loads connected in a system and due to one of fault load a large outrush current is drawn (demanded), this will be detected by APB. This APB can trip the external output protection device with appropriate rating based on system load. Thus preventing the system from shutting down while other connected current paths continue to operate without interruption.

The following waveforms demonstrate the behavior.

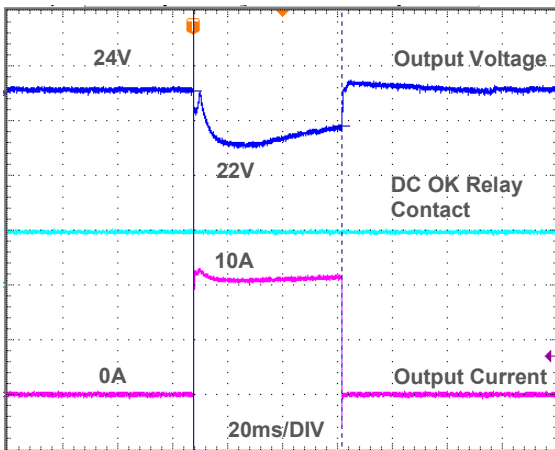

Fig. 8.1 APB 200% of nominal output current for 50ms

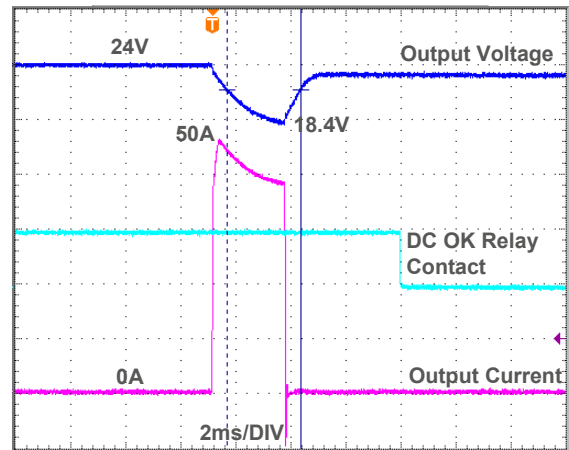

Fig. 8.2 APB 500% of nominal output current for 2ms

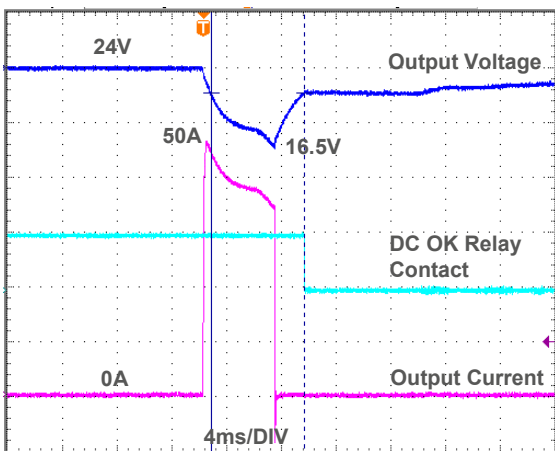

Fig. 8.3 APB 500% of nominal output current for 5ms

External Input Protection Device

The unit is protected with internal fuse (not replaceable) at L pin and it has been tested and approved on 20A (UL) and 16A (IEC) branch circuits without additional protection device. An external protection device is only required if the supplying branch has an ampacity greater than above. Thus, if an external protective device is necessary, or, utilized, please refer a minimum value in instruction sheet with B or C characteristic breaker.

CliQ VA DIN Rail Power Supply

24V 240W 1 Phase / DRV-24V240W1PN



Operating Mode

■ Redundant Operation

In order to ensure proper redundant operation for the power supply units (PSUs), the output voltage difference between the two units must be kept at 0.45~0.50V for these 24V supplies. Follow simple steps given below to set them up for the redundant operation:

Step 1.

Measure output voltage of PSU 1 and PSU 2. If PSU 1 is the master unit, then V_O of PSU 1 must be higher than PSU 2. In order to set the output voltage, individually connect each power supply to 50% of rated load at any line voltage from 85-264Vac, and set the PSU 1 and PSU 2 output voltage.

Step 2.

Connect the power supply units PSU 1 and PSU 2 to Vin 1 & Vin 2, respectively, of the DRR-20N (or 20A) module shown on the right of above diagram.

Step 3.

Connect the system load to V_{out} . Please note that output voltage V_{out} from DRR module will be = V_O (output voltage of power supply) – V_{drop}^* (in DRR module).

* V_{drop} will vary from 0.60V to 0.90V (Typical 0.65V) depending on the load current and surrounding air temperature.

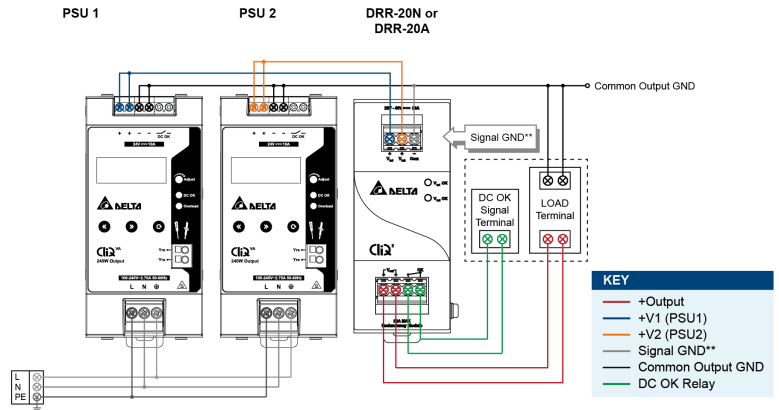

**The Signal GND in the DRR module is for the built-in LED and DC OK signals. The Output GND terminals from the two PSU's do not need to be connected to the Signal GND terminal.

Fig. 9 Redundant Operation Connection Diagram

■ Parallel Operation

The power supply units (PSUs) can also be used for parallel operation in order to increase the output power. The difference in output voltage between the two units must be kept to within 25mV of each other. This difference must be verified with the same output load connected independently to each unit.

Parameters such as EMI, inrush current, leakage current, PARD, start up time will be different from those on the datasheet, when two units are connected in parallel. The user will need to verify that any differences will still allow the two power supplies connected in parallel will work properly in their product/application.

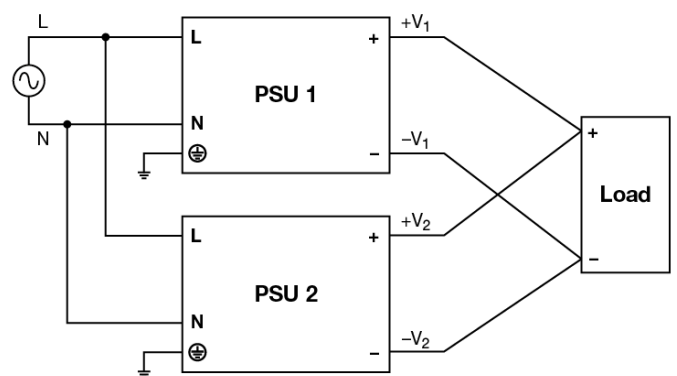

Fig. 10 Parallel Operation Connection Diagram

CliQ VA DIN Rail Power Supply

24V 240W 1 Phase / DRV-24V240W1PN

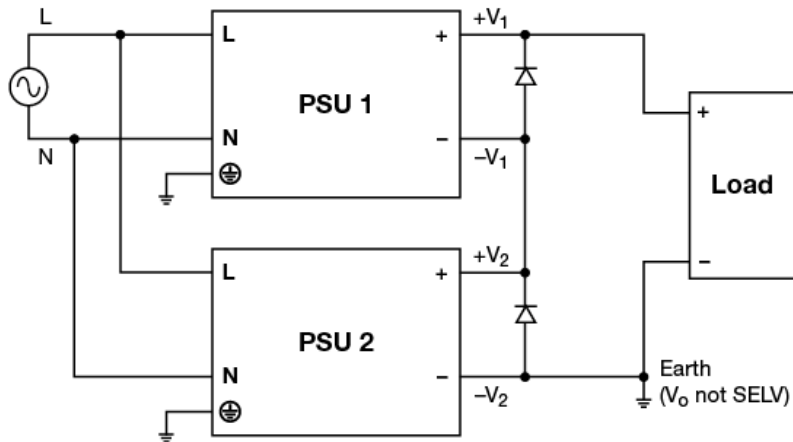
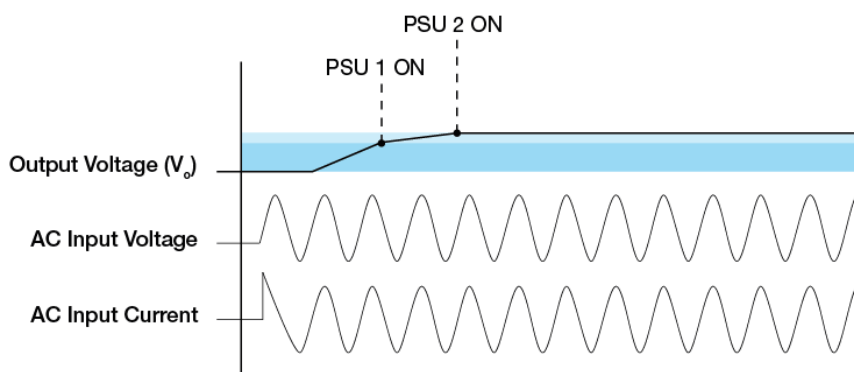

Fig. 11 Series Operation Connection Diagram

Series Operation

Delta's CliQ VA can be connected in series to increase the output voltage as shown in figure above. Power supply from the same product series only be used and with the same rated output current. The maximum load current should not exceed the smallest rated output current. Any number of power supplies can be connected in series, user must note that output voltage > 60Vdc will not meet SELV requirements and could be dangerous to user, the total voltage shall not exceed 150Vdc. Installation a protection against the touching is a must and connect the output ground to earth when output voltage is not SELV. A diode in reverse bias must be added across output terminals of each power supply, this is to prevent -V voltage being applied to other power supply in fault conditions such as short circuit across load. During short circuit -V₁ & +V₁ will come across +V₂ & -V₂ which means connecting 2 power supplies in opposite polarity and may cause damage to power supply. With reverse bias diodes in place the voltage across each power supply will be restricted to one diode drop – approximately 0.7V to 1.0V. It is recommended to provide sufficient de-rating for diodes use 2 times the voltage rating of series output voltage. E.g. the two 24V power supplies are connected in series, the total voltage is 48 volts. Hence, recommended to use diodes with reverse voltage rating of 2x48=96 volts. Therefore diodes with reverse voltage rating of 100 volts can be used.

During the short circuit condition, the current through diodes will be large, hence it is recommended that diodes to be least twice the current rating of the power supply.



The turn ON would be non-monotonic as the power supply with the fastest startup time and rise time will turn on first. As a result, the startup waveform with 2 power supplies connected in series would see a step.

User must consider to verify parameters such as EMI, inrush current, leakage current, PARD, start up time would differ from datasheet numbers as multiple power supplies in series.

CliQ VA DIN Rail Power Supply

24V 240W 1 Phase / DRV-24V240W1PN

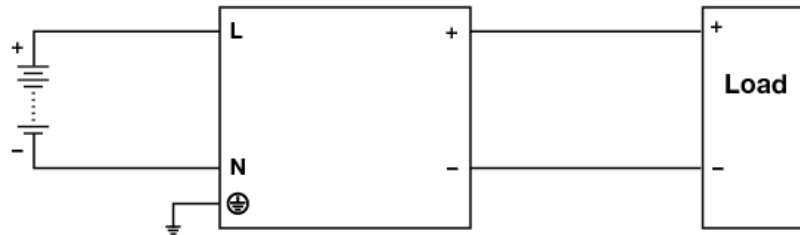

Fig. 12 DC Input Operation Connection Diagram

■ DC Input Operation

Step 1.
Use a battery or similar DC source.

Step 2.
Connect +pole to L and -pole to N.

Step 3.
Connect the PE terminal to an earth wire or to the machine ground.

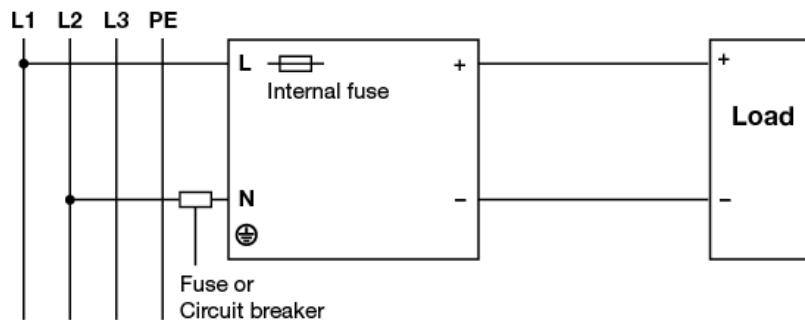

Fig. 13 2 of 3 Phase System Input Operation Connection Diagram

■ 2 of 3 Phase System Input Operation

Delta's CliQ VA can use on 2 of 3 phase system. Please refer to the following step.

Step 1.
The supplying voltage is below the maximum rated input. The input voltage shall be below 240Vac +10%.

Step 2.
The external protector is needed on N input line to secure a safety. N line has no protection of a fuse internally. An appropriate fuse or circuit breaker should be connected on N input line like the following.

CliQ VA DIN Rail Power Supply

24V 240W 1 Phase / DRV-24V240W1PN



Others

Delta RoHS Compliant



Restriction of the usage of hazardous substances

The European directive 2011/65/EU limits the maximum impurity level of homogeneous materials such as lead, mercury, cadmium, chrome, polybrominated flame retardants PBB and PBDE for the use in electrical and electronic equipment. RoHS is the abbreviation for "Restriction of the use of certain hazardous substances in electrical and electronic equipment".

This product conforms to this standard.

Conformal Coating

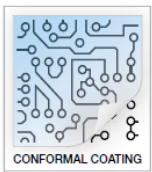

The Protective Coating Technology

Delta Electronics Group has designed the perfect dipping technique which penetrates everywhere including under device, and prevents leakage. The conformal coating dipping can be applied to PCBAs or circuit board. The coating preserves the performance of precision electronic primarily by preventing ionizable contaminants such as salt from reaching circuit nodes, where the material slumps around sharp edges. This can be a problem especially in highly conversing atmosphere.

PFC – Norm EN 61000-3-2

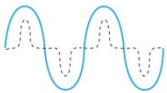

Line Current Harmonic content

Typically, the input current waveform is not sinusoidal due to the periodical peak charging of the input capacitor. In industrial environment, complying with EN 61000-3-2 is only necessary under special conditions. Complying to this standard can have some technical drawbacks, such as lower efficiency as well as some commercial aspects such as higher purchasing costs. Frequently, the user does not profit from fulfilling this standard, therefore, it is important to know whether it is mandatory to meet this standard for a specific application.

Attention

Delta provides all information in the datasheets on an "AS IS" basis and does not offer any kind of warranty through the information for using the product. In the event of any discrepancy between the information in the catalog and datasheets, the datasheets shall prevail (please refer to www.DeltaPSU.com for the latest datasheets information). Delta shall have no liability of indemnification for any claim or action arising from any error for the provided information in the datasheets. Customer shall take its responsibility for evaluation of using the product before placing an order with Delta.

Delta reserves the right to make changes to the information described in the datasheets without notice.



TS Connect AB / Power Outlet
Fagerstagatan 9, 163 53 Spånga, Stockholm, Sweden
Web: www.power-outlet.com / Web: www.tsconnect.se
Mail: sales@power-outlet.com / Phone: +46 8 795 93 10