

Chrome DC-UPS Module

24V 10A / DRU-24V10ACZ



CHROME



Highlights & Features

- Suitable for 24V system up to 10A
- Zero switch over time from loss of DC input to battery operation
- Built-in diagnostic monitoring for DC OK
- Discharge and Battery Fail by relay contacts
- Full power over entire operating temperature range from 20°C to +60°C
- LED indicators for DC OK,
- LED Indicator for Battery Charging Battery Discharging
- LED Indicator for Battery Fail and Battery Reverse Polarity
- High MTBF > 500,000 hrs. as per Telcordia SR-332
- Over Voltage / Over Current / Over Temperature / Short Circuit Protections

Safety Standards



CB Certified for worldwide use

Model Number: DRU-24V10ACZ
Unit Weight: 0.14 kg (0.31 lb)
Dimensions (L x W x D): 91.0 x 71.0 x 55.6 mm
 (3.58 x 2.80 x 2.19 inch)

General Description

Delta's Chrome DC-UPS module is designed to use in small cabinets where space is very critical. The module requires less installation space due to its flat body with depth of only 55.6mm, 71mm wide and 91mm tall. The tough plastic case has flame retardant property certified to UL 94V-0 specification. The module supports 24Vdc system with external battery up to 12AH capacity and comes with potential free contacts for battery management signals and LED indicator for battery status. The highly efficient convection cooled design is certified to major safety approvals including IEC/EN/UL 60950-1 for ITE and UL 508 for Industrial, which allows the module to be used reliably in most industrial applications.

Model Information

Chrome DC-UPS Module

Model Number	Input Voltage Range	Rated Output Voltage	Rated Output Current
DRU-24V10ACZ	24-28Vdc	24Vdc typ. (Depends on V _{in})	10.0A Max

Model Numbering

DR	U –	24V	10A	C	Z
DIN Rail	DC-UPS Module	Output Voltage	Output Current	Chrome Series	Z – Black Plastic Case, without Class I, Div 2



Chrome DC-UPS Module

24V 10A / DRU-24V10ACZ



Specifications

Input Ratings / Characteristics

Nominal Input Voltage		24Vdc
Input Voltage Range		24-28Vdc
Input Current	Charging Mode	0.5A ± 0.1A
Charging Time*		< 30hr ± 5hr for battery 24V/12AH
Efficiency	Charging Mode	> 80.0%
	Buffering Mode	> 99.0%

*Charging time depends on the last state of discharged battery w.r.t. buffering time and load current.

Output Ratings / Characteristics

Output Voltage Range		23-28Vdc
Output Current		10.0A Max
Output Power		240W Max (24V, 10A)
Voltage Drop Between Input and Output	Charging Mode	0.2V between DC input to load
	Buffering Mode	0.3V between battery to load @ 10A load

Battery Input / Output Characteristics

Nominal Battery Voltage	24Vdc, SLA Sealed lead acid battery 2 x 12Vdc, SLA Sealed lead acid battery
Battery Voltage Range	23-28Vdc (continuously operating) 33Vdc Max (the maximum voltage that will not cause damage to the unit) 20Vdc Min (the voltage level of battery to enable "BAT Fail" function)
Battery Capacity	3.3AH to 12AH
Battery Fuse	Auto 15A / 58V, MINI (Littelfuse) or similar in the battery path. The battery fuse protects the wires between the battery and the unit.
Battery Charging Mode	CC-CV mode (constant current-constant voltage) at 0.5A
End-of-Charge Voltage	The unit always charges with fix input voltage value

Chrome DC-UPS Module

24V 10A / DRU-24V10ACZ



Buffering Time

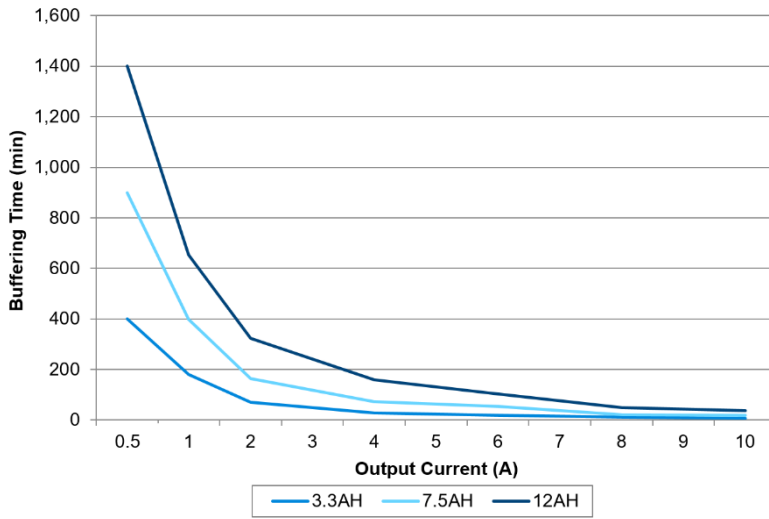

Output Current	Buffering Time (min)		
	3.3AH	7.5AH	12AH
0.5A	400	900	1400
1A	180	398	654
2A	70	165	323
4A	28	72	160
6A	19	55	103
8A	11	22	49
10A	7	18	37

Fig. 1 Buffering Time VS. Output Current

Mechanical

Case Cover / Chassis	Plastic	
Dimensions (L x W x D)	91.0 x 71.0 x 55.6 mm (3.58 x 2.80 x 2.19 inch)	
Unit Weight	0.14 kg (0.31 lb)	
LED Indicator	Green LED	DC OK, Battery Charging (flash)
	Red LED	Battery Fail
	Orange LED	Reverse polarity, Battery Discharging (flash)
Cooling System	Convection	
Terminal	Input / Output / Battery	6 Pins (Rated 300V/25A)
	Signal	6 Pins (Rated 300V/25A)
Wire	Input / Output / Battery	AWG 24-12
	Signal	AWG 24-12
Mounting Rail	Standard TS35 DIN Rail in accordance with EN 60715	
Noise (1 Meter from power supply)	Sound Pressure Level (SPL) < 40dBA	

Chrome DC-UPS Module

24V 10A / DRU-24V10ACZ



Environment

Surrounding Air Temperature	Operating	-20°C to +60°C (full power)
	Storage	-25°C to +85°C
Operating Humidity		5 to 95% RH (Non-Condensing)
Operating Altitude		0 to 3,000 Meters
Shock Test	Operating	IEC 60068-2-27, Half Sine Wave: 4G for a duration of 22ms, 3 time per direction, 9 times in total
	Non-Operating	IEC 60068-2-27, Half Sine Wave: 50G for a duration of 11ms, 3 time per direction, 9 times in total
Vibration	Operating	IEC 60068-2-6, Sine Wave: 10Hz to 500Hz @ 19.6m/S ² (2G peak); 10 min per cycle, 60 min for all X, Y, Z directions
	Non-Operating	IEC 60068-2-6, Random: 5Hz to 500Hz @ 2.09Grms); 20 min per axis for all X, Y, Z directions
Pollution Degree		2

Protections

Overvoltage	Buffering Mode	33Vdc Max will not cause damage to the unit, Latch Mode
Overload / Overcurrent	Buffering Mode	< 18A, Latch Mode
Over Temperature	Buffering Mode	< 90°C Surrounding Air Temperature inside the unit, Latch Mode
Short Circuit (at system)	Buffering Mode	Shutdown, Latch Mode
Input Polarity Protection*		Yes (DC OK = open contact, LED Status = Orange)
Battery Polarity Protection*		Yes (DC OK = open contact, LED Status = Orange)
Wrong Battery Voltage Protection		Shutdown, 35V Max (the maximum voltage that will not cause damage to the unit)
Deep Discharge Protection		Yes (22V ± 1V)**
Degree of Protection		IP20
Protection Against Shock		Class III

*If the orange status LED is on, this indicates a failure in the installation. In this case, do not turn on power supply while the battery is connected. Danger of explosion!

** The unit will stop operating when the battery voltage detected is less than 22V ± 1V

Reliability Data

MTBF	> 500,000 hrs. as per Telcordia SR-332
------	--

Chrome DC-UPS Module

24V 10A / DRU-24V10ACZ



Safety Standards / Directives

Electrical Equipment of Machines		EN 60204-1
Electrical Equipment in Power Installations		EN 62477-1 / IEC 62103-1
Safety Entry Low Voltage		SELV (EN 60950-1) PELV (EN 60204-1, EN 62477-1)
Electrical Safety	SIQ Bauart	EN 60950-1
	UL/cUL recognized	UL 60950-1 and CSA C22.2 No. 60950-1 (File No. E191395)
	CB scheme	IEC 60950-1
Industrial Control Equipment	UL/cUL listed	UL 508 and CSA C22.2 No. 107.1-01 (File No. E315355)
CE		In conformance with EMC Directive 2014/30/EU and Low Voltage Directive 2014/35/EU
Material and Parts		RoHS Directive (2011/65/EU)
Galvanic Isolation	Power Port to Signal Port	1.0kVac
	Power Port to Housing	-
	Signal Port to Housing	-

EMC

Emissions (CE & RE)		CISPR 32, EN 55032, EN 55011, FCC Title 47: Class B
Component Power Supply for General Use		EN 61204-3
Immunity		EN 55024, EN 61000-6-2
Electrostatic Discharge	IEC 61000-4-2	Level 4 Criteria A ¹⁾ Air Discharge: 15kV Contact Discharge: 8kV
Radiated Field	IEC 61000-4-3	Level 3 Criteria A ¹⁾ 80MHz-1GHz, 10V/M, 80% modulation (1KHz) 1.4GHz-2GHz, 3V/M, 80% modulation (1KHz) 2GHz-2.7GHz, 1V/M, 80% modulation (1KHz)
Electrical Fast Transient / Burst	IEC 61000-4-4	Level 3 Criteria A ¹⁾ 2kV (Input power ports)
Surge	IEC 61000-4-5	Level 2 Criteria A ¹⁾ 0.5kV (Input power ports)
Conducted	IEC 61000-4-6	Level 3 Criteria A ¹⁾ 150kHz-80MHz, 10Vrms
Power Frequency Magnetic Fields	IEC 61000-4-8	Criteria A ¹⁾ 10A/Meter

1) Criteria A: Normal performance within the specification limits

Chrome DC-UPS Module

24V 10A / DRU-24V10ACZ



Block Diagram

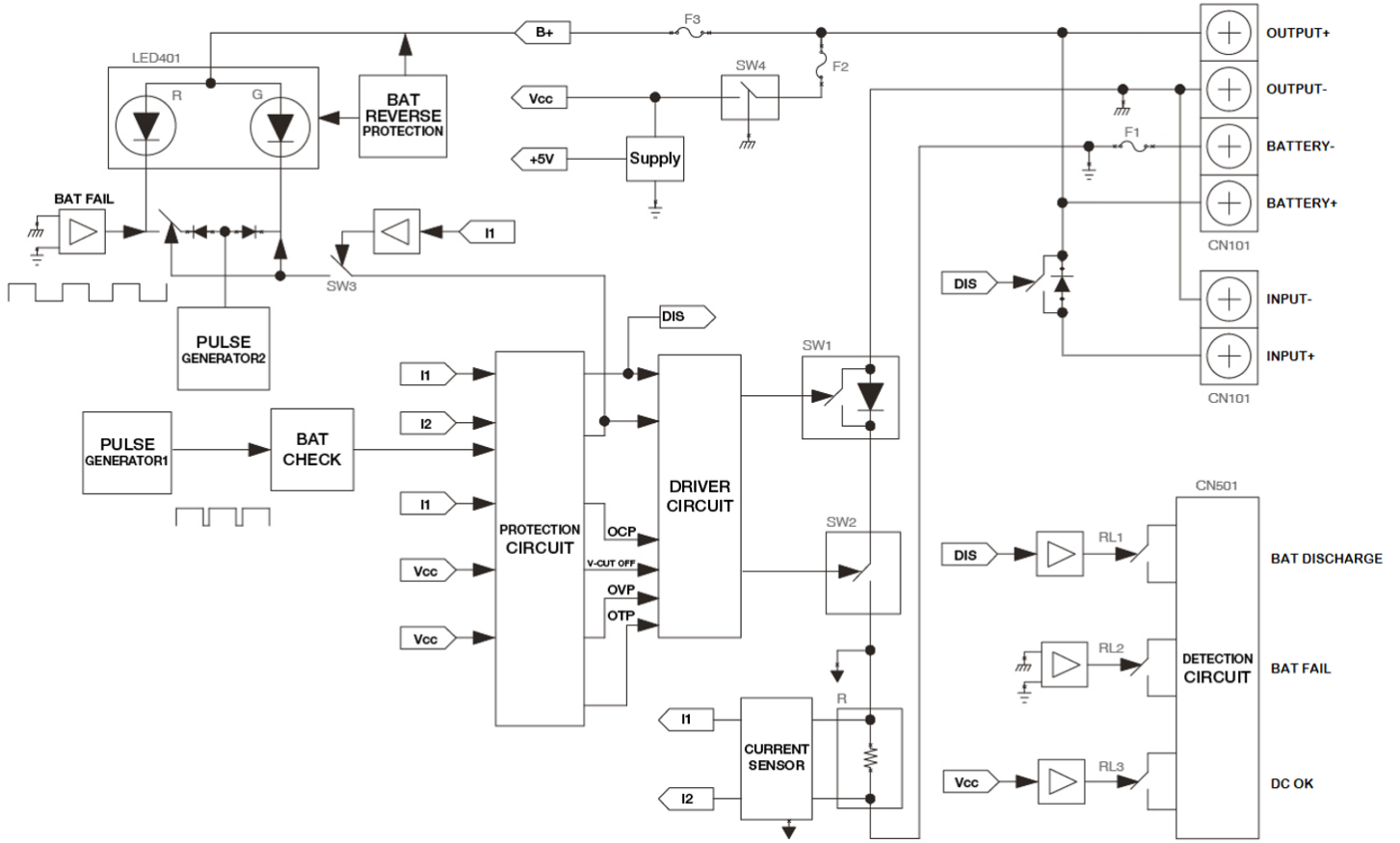

Device Description

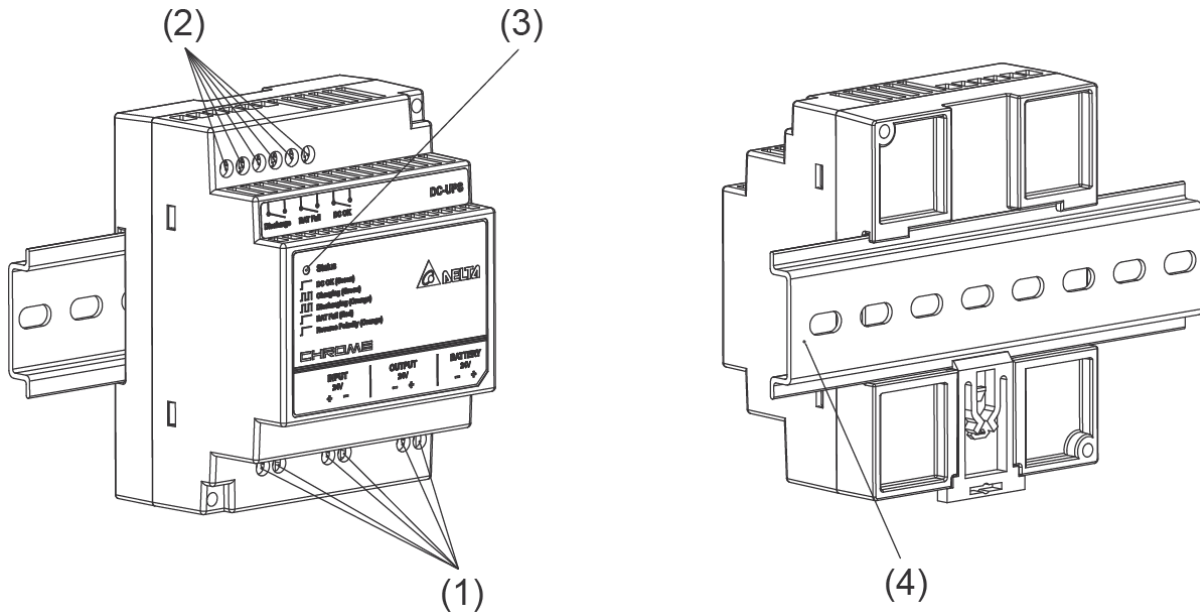

- 1) Input / Output / Battery terminal block connector
- 2) Signal terminal block connector
- 3) LED display status
- 4) Universal mounting rail system



Chrome DC-UPS Module

24V 10A / DRU-24V10ACZ



Dimensions

L x W x D: 91.0 x 71.0 x 55.6 mm (3.58 x 2.80 x 2.19 inch)

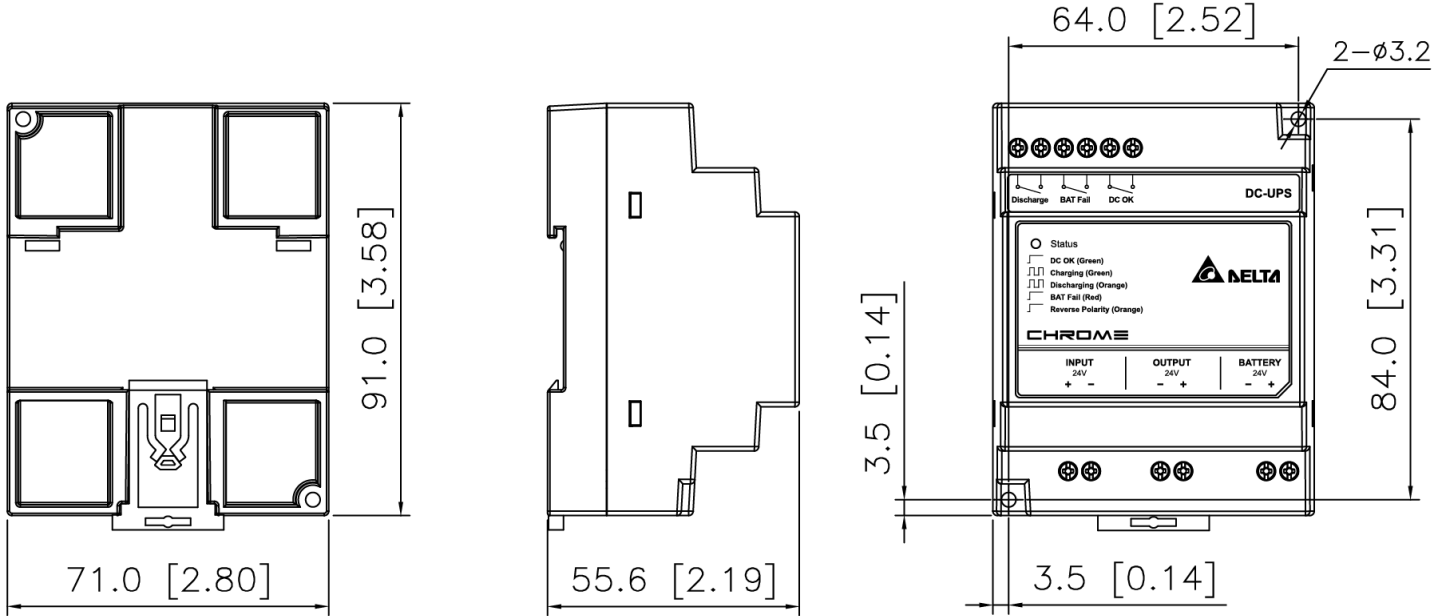

Engineering Data

Output Load De-rating VS Surrounding Air Temperature

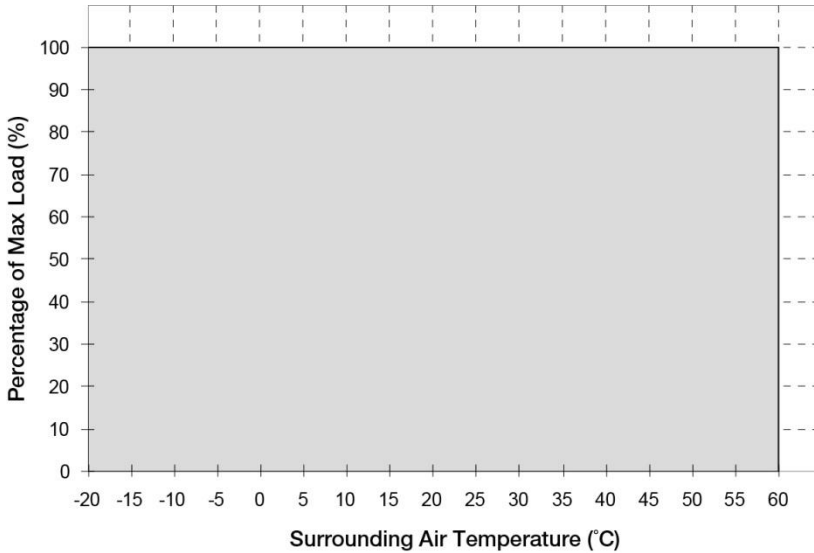

Fig. 2 No power de-rating across the entire operating temperature range (-20°C to +60°C)

Note

1. The unit may degrade, or be damaged, when it is continuously used outside the shaded region, refer to the graph shown in Fig. 2.
2. When the DC-UPS module is used with power supply of different ratings, user must follow power supply derating curve or whichever is lower.
3. In order for the device to function in the manner intended, it is also necessary to keep a safety distance of 20mm above and below the device as well as a lateral distance of 5mm with adjacent units while the device is in operation.
4. Depending on the surrounding air temperature and output load delivered by the power supply, the device can be very hot!
5. If the device has to be mounted in any other orientation, please contact info@deltapsu.com for more details.

Chrome DC-UPS Module

24V 10A / DRU-24V10ACZ



Assembly & Installation

The unit can be mounted on 35mm DIN rails in accordance with EN 60715. For Vertical Mounting, the device should be installed with Input / Output / Battery terminal block on the bottom.

Each device is delivered ready to install.

Mounting

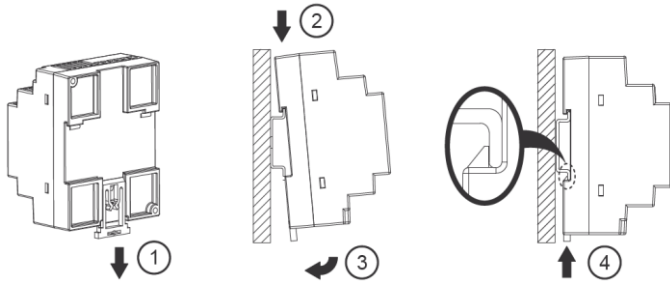

Fig. 3.1 Mounting

Snap on the DIN rail as shown in Fig. 3.1:

1. Pull the unit's DIN rail latch DOWN.
2. Tilt the unit slightly upwards, hook the top end onto the DIN rail and push downwards until stopped.
3. Position the bottom front end against the DIN rail.
4. Push the unit's latch DIN rail UP to lock.

Dismounting

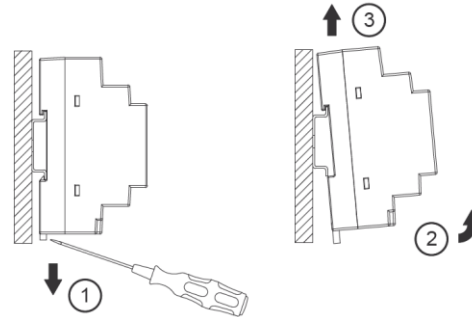
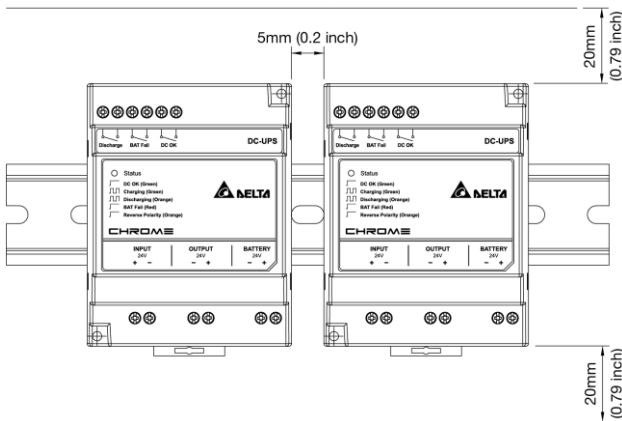

Fig. 3.2 Dismounting

To uninstall,

1. Pull the unit's DIN rail latch DOWN.
2. Tilt the bottom part of the unit out.
3. Push the unit up and pull out from the DIN rail.

Safety Instructions



- When replacing batteries, only use the same type of batteries listed under the "Battery Input / Output Characteristics" section on Page 2.
- Proper disposal of batteries is required. Refer to the relevant local codes for disposal requirements.
- ALWAYS switch mains of input power OFF before connecting and disconnecting the input voltage to the unit. If mains are not turned OFF, there is risk of explosion / severe damage.
- Orange LED will be on if one of Battery/Input connector is reverse polarity while the other connectors are not connect, check polarity connection and make corrections.
- If the orange status LED is on, this indicates a failure in the installation. In this case, do not turn on power supply while the battery is connected. Danger of explosion!
- **To guarantee sufficient convection cooling, keep a distance of 20mm (0.79 inch) above and below the device as well as a lateral distance of 5mm (0.2 inch) to other units.**
- Note that the enclosure of the device can become very hot depending on the surrounding air temperature and load of the power supply. Risk of burns!
- The main power must be turned off before connecting or disconnecting wires to the terminals!
- DO NOT insert any objects into the unit.
- Hazardous voltages may be present for up to 5 minutes after the input mains voltage is disconnected. Do not touch the unit during this time.
- The unit is a built-in unit and must be installed in a cabinet or room (condensation free environment and indoor location) that is relatively free of conductive contaminants.

Chrome DC-UPS Module

24V 10A / DRU-24V10ACZ



Functions

Relay Contacts Characteristics

Max Relay Contact Rating		24Vdc/Vac, 0.5A
DC BUS OK	Relay Contact	“DC OK” contact is closed when the DC input voltage is within 24-28V ($\pm 1V$) range or the battery voltage is within 23-28V range
	LED Indicator	ON (Green)
Charging	Relay Contact	“DC OK” contact is closed when the unit is in charging mode
	LED Indicator	Flashing (Green)
Battery Discharge ¹⁾	Relay Contact	“Discharging” contact is closed when the unit is in buffering mode
	LED Indicator	Flashing (Orange)
Battery Fail ²⁾	Relay Contact	“BAT Fail” contact is closed when the battery fails to function or battery voltage is less than $20V \pm 1V$
	LED Indicator	ON (Red)
Battery Reverse Polarity	Relay Contact	All contact are opened when the battery is in reverse polarity
	LED Indicator	ON (Orange)
Input Reverse Polarity ³⁾	Relay Contact	All contact are opened when the input is in reverse polarity
	LED Indicator	ON (Orange)

1) Relay contact & LED indicator are functional with output current from 0.1A to 10A range, < 0.1A it is intermittent.

2) While replacing the FAIL battery with system in ON State, user MUST wait for 30secs after removing the FAIL battery and replace with new. In case the user replaces battery within 30secs and accidentally connects the battery in reverse polarity, this may cause the **DC-UPS MODULE TO BE DAMAGED!**

3) In this case, power supply is Turned ON with full system configuration (as shown in fig 4.1) the module will indicate if the input connections are reverse.

Signals Wiring Diagram

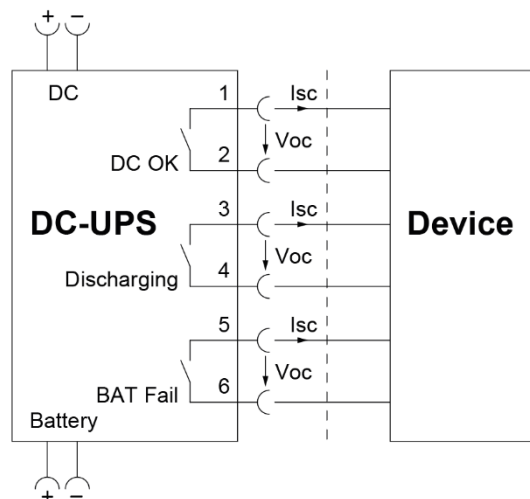

DC-UPS Status	Relay Output Connector			LED Display Status
	Discharging	BAT Fail	DC OK	
Battery Charging	Open	Open	Close	Flashing (Green)
Battery Fully Charged	Open	Open	Close	ON (Green)
Battery Discharging* (Buffering Mode)	Close	Open	Close	Flashing (Orange)
No Battery Connected	Open	Close	Open	ON (Red)
Output Shutdown	Open	Open	Open	OFF

*With output current 0.1A to 10A.

Chrome DC-UPS Module

24V 10A / DRU-24V10ACZ



Charging Mode

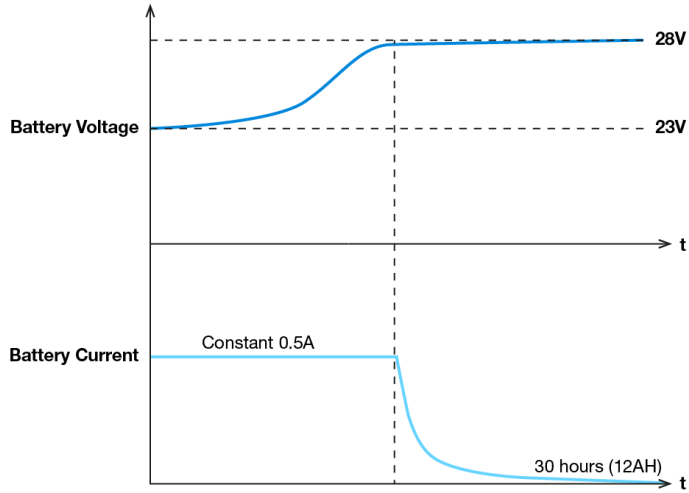

Buffering Mode

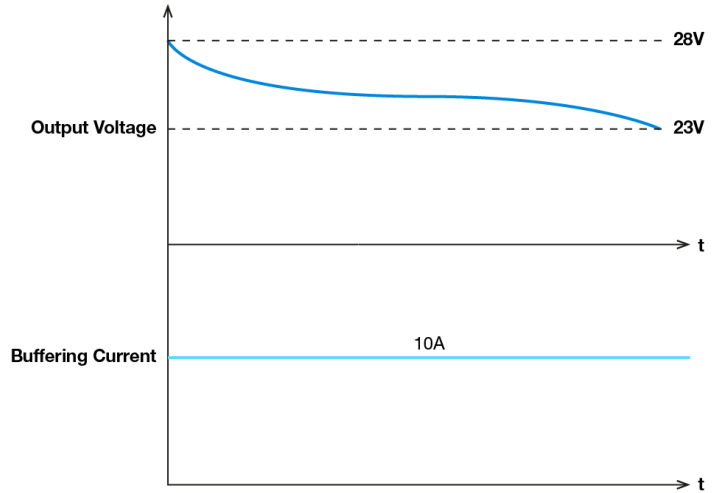

Typical Application Notes

Fig. 4.1 Provide backup power during AC source interruption or failure

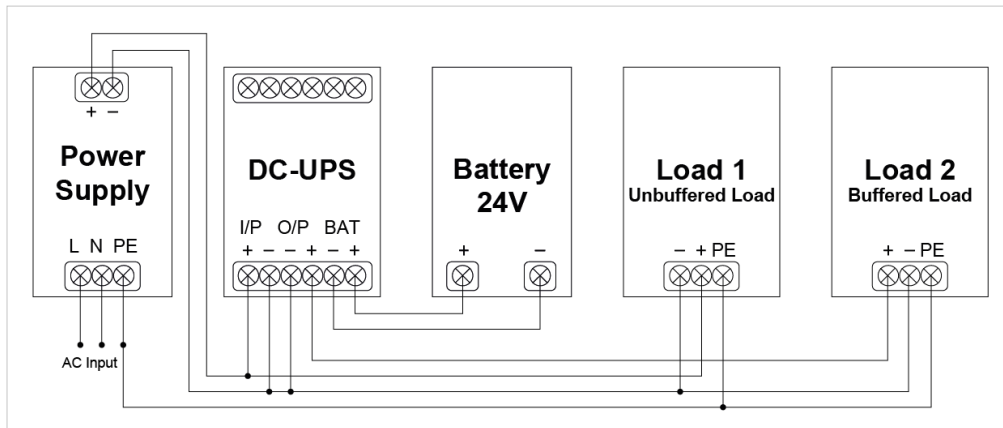
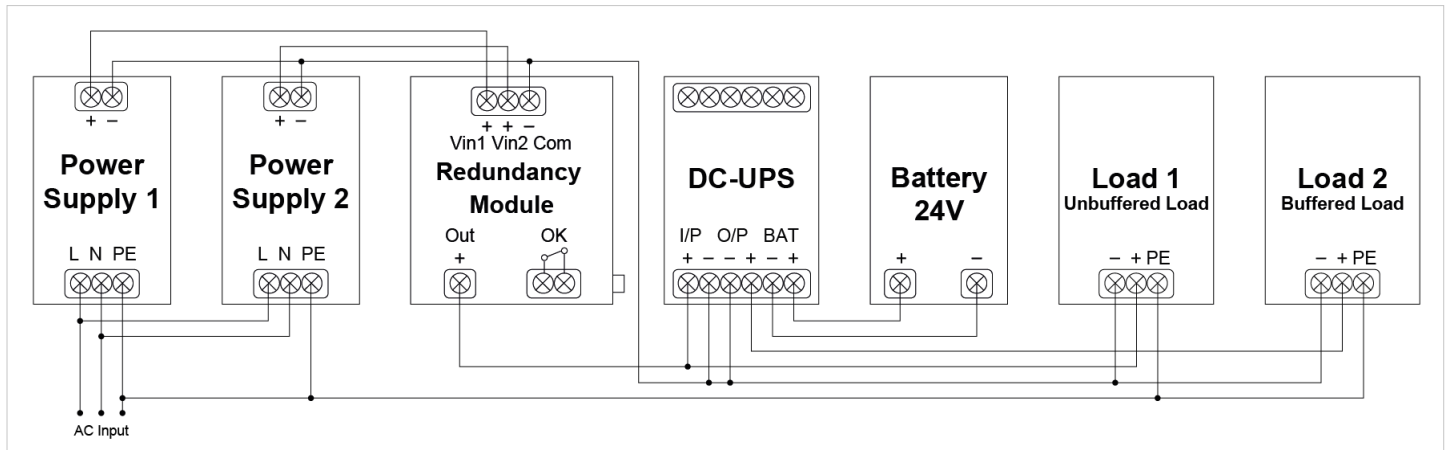

Fig. 4.2 Can be combined with redundancy module (DRR-20A)



Chrome DC-UPS Module

24V 10A / DRU-24V10ACZ



Overload & Overcurrent Protections (Latch Mode)

When the output current exceeds the maximum specified output current. The DC-UPS module will shut down and protect itself. Normal operation of the module can be resumed upon removal of fault and re-application of input voltage.

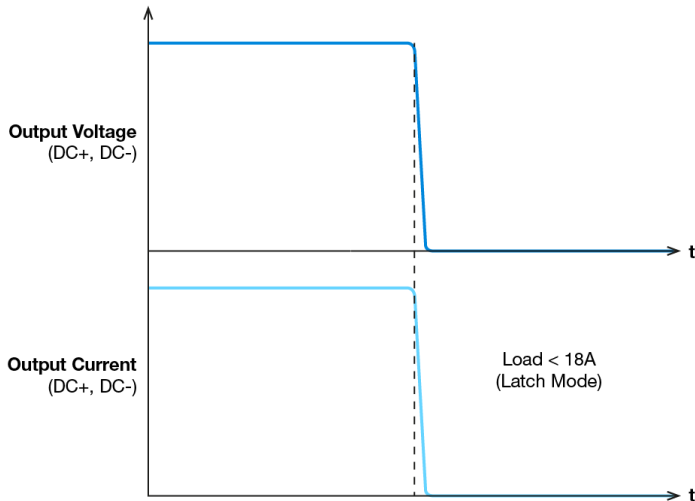

Overvoltage Protection (Latch Mode)

The DC-UPS module's overvoltage protection will be activated when DC input to the module exceeds the maximum specified input voltage. The unit shall shutdown and return to normal state when the OVP condition is removed. Removal/re-application of input voltage will then be required in order to restart.

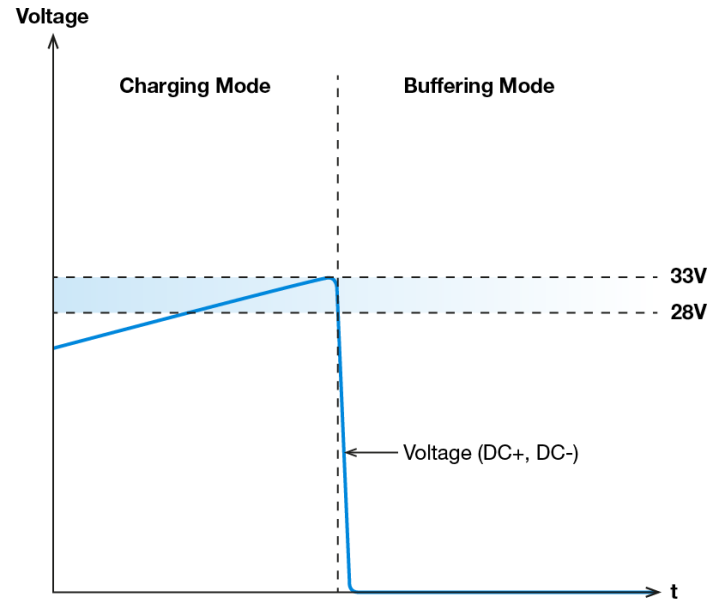

Short Circuit Protection (Latch Mode)

The module is protected in case of short circuit at customer system, in the event of short circuit the module will shut down and protect itself. Normal operation can be resumed upon removal of fault and re-application of input voltage.

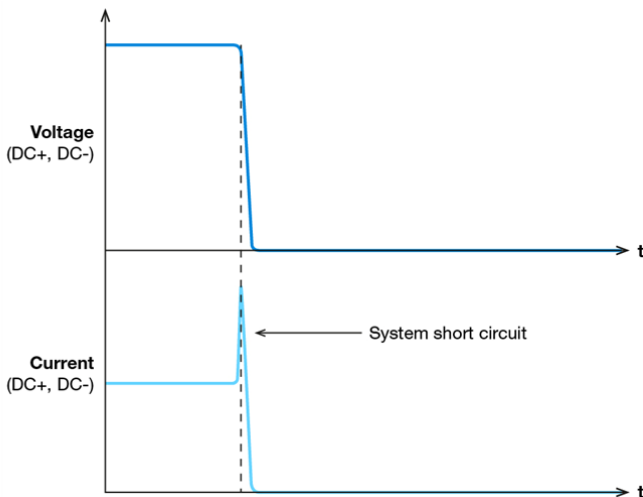

Over Temperature Protection (Latch Mode)

In the event of a higher operating temperature at 100% load, the power supply will run into OTP when the operating temperature is beyond what is recommended in the de-rating graph. When activated, the output voltage will shut down and remain in off state until the temperature drops to its normal operating temperature as recommended in the de-rating graph. Removal/re-application of input voltage will then be required in order to restart.

Chrome DC-UPS Module

24V 10A / DRU-24V10ACZ



Troubleshooting

Problem	Possible Cause	Suggestion
Orange LED is ON (While other connections are not done)	Battery connection is reverse polarity.	Check polarity connection and make corrections.
Orange LED is ON (Battery Connection is Correct) (Output Connection is Correct)	Input connection is reverse polarity. (With power supply connected and Turned ON)	Check polarity connection and make corrections.
DRU does not operate in charging mode after input is applied	Input wiring is open or input voltage to the supply is not available.	Check wiring and voltage of input supply.
	Internal fuse is opened.	Contact your local Delta sales support group.
DRU does not operate in buffering mode after input is collapsed	Battery wiring is not connected or opened.	Check battery wiring and compare with Typical Application Notes in this DRU datasheet. Make corrections as needed.
	Battery does not have enough time to be charged and it is still below the continuous operating voltage range.	Check battery voltage and compare with minimum required battery voltage provided in this DRU datasheet.
	Protection mode enable.	Check DRU condition with protection condition.
Relay contact status does not match with LED status	DRU has some problem.	Contact your local Delta sales support group.

Others

Delta RoHS Compliant



Restriction of the usage of hazardous substances

The European directive 2011/65/EU limits the maximum impurity level of homogeneous materials such as lead, mercury, cadmium, chrome, polybrominated flame retardants PBB and PBDE for the use in electrical and electronic equipment. RoHS is the abbreviation for "Restriction of the use of certain hazardous substances in electrical and electronic equipment".

This product conforms to this standard.

Conformal Coating



The Protective Coating Technology

Delta Electronics Group has designed the perfect dipping technique which penetrates everywhere including under device, and prevents leakage. The conformal coating dipping can be applied to PCBs or circuit board. The coating preserves the performance of precision electronic primarily by preventing ionizable contaminants such as salt from reaching circuit nodes, where the material slumps around sharp edges. This can be a problem especially in highly conversing atmosphere.

Attention

Delta provides all information in the datasheets on an "AS IS" basis and does not offer any kind of warranty through the information for using the product. In the event of any discrepancy between the information in the catalog and datasheets, the datasheets shall prevail (please refer to www.DeltaPSU.com for the latest datasheets information). Delta shall have no liability of indemnification for any claim or action arising from any error for the provided information in the datasheets. Customer shall take its responsibility for evaluation of using the product before placing an order with Delta.

Delta reserves the right to make changes to the information described in the datasheets without notice.



TS Connect AB / Power Outlet
 Fagerstagatan 9, 163 53 Spånga, Stockholm, Sweden
 Web: www.power-outlet.com / Web: www.tsconnect.se
 Mail: sales@power-outlet.com / Phone: +46 8 795 93 10

